



Curriculum Guide to S3 For Pupils and Parents

February 2018



St Augustine's RC High School
Broomhouse Road
Edinburgh
EH12 9AD

Tel 0131 334 6801

Fax 0737 334 7329

Email admin@st-augustines.edin.sch.uk

Website staugustinesrchs.uk

This guide is written with S3 as our target audience
We hope that parents will find it useful too

Introduction

Dear Student

As you move into S3, you will be coming to the end of your Broad General Education which you began in primary school. As you move through school, you are faced with many different choices. Of course, when you leave school, you have to make choices all the time.

How will you earn your living? Where will you work? Where will you live?

In S3 you continue to have breadth in the subjects you study – this is important so that as adults you will have a good general knowledge. However, it is now time to start specialising with a view to thinking about what you might like to do when you leave school.

We are all different and the next few years will see us all following different pathways in our learning.

Pathway 1 – Studying till the end of S4 with a view to going to college or undertaking a modern apprenticeship or employment

Pathway 2 - Studying till the end of S5 with a view to going to college or undertaking a modern apprenticeship or employment

Pathway 3 – Studying till the end of S6 with a view to going to university

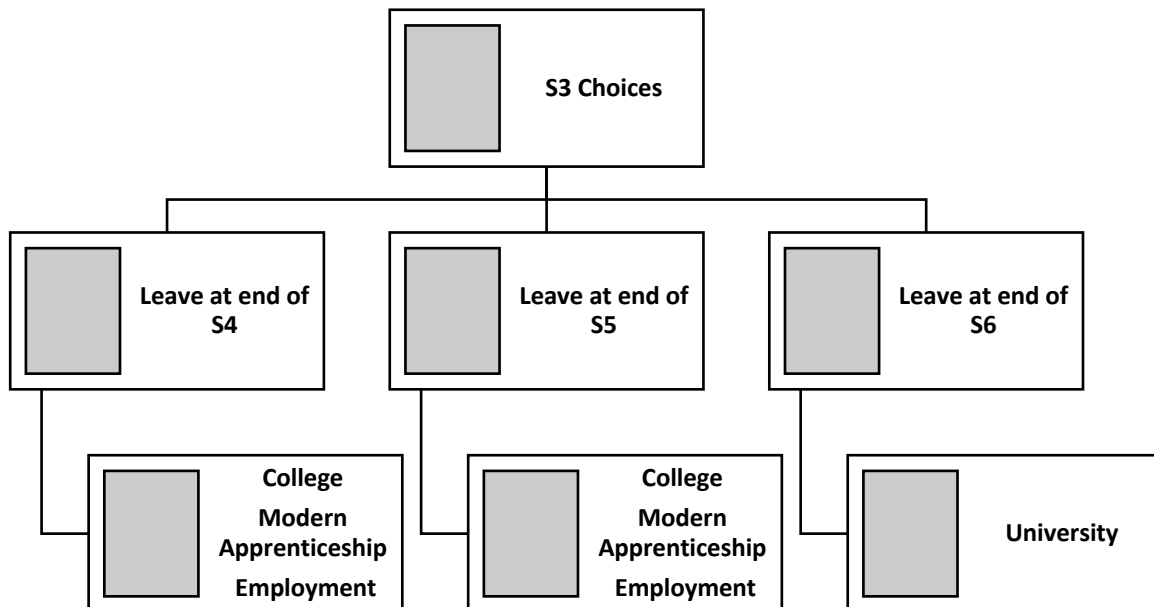

In preparation for S3, we are asking you to review your learning in S2 and consider which pathway you will likely follow. We have included in this booklet likely subject choices for S4 and S5 to help with your planning.

To help you choose wisely, we have prepared this guide which:

- Outlines what to consider when making subject choices
- Tells you how we will help
- Gives you more information on the S3 curriculum.

At the **S2 Parents' Information Evening**, your parents will have the opportunity to learn more about S3 and the Senior Phase and to ask any questions about the options available to you.

At the **S2 Parents' Consultation Evening**, your parents will be able to discuss your Report with your teachers and identify your strengths.

In addition, your Pupil Support Leader will support you and your family with lots of advice and an opportunity to discuss your learning choices for S3.

We want to support you in making S3 a successful year at St Augustine's.

Michael McGee
Head Teacher

Contents

- The Curriculum
- Support
- Personalisation and Choice
- S3 Courses

The Curriculum

In S3, subjects are grouped into **Curricular Areas**, and pupils are required to study within **all** of these for **all** three years and, in the main, with no formal examinations via the Scottish Qualifications Authority.

This is a change from previous years when pupils embarked on examination courses that lasted from the beginning of S3 to the end of S4.

These Curricular Areas are:-

<i>Curricular Areas</i>	<i>Subjects</i>
Languages and Literacy	English, Modern Languages
Mathematics and Numeracy	Mathematics
Religious & Moral Education	Religious Education
Health and Well-Being	Physical Education, Home Economics (eg diet & nutrition), Personal & Social Education
Science	Biology, Chemistry, Physics
Social Studies	Geography, History, Modern Studies
Technology	Business Education, Computer Education Craft & Design, Home Economics
Expressive Arts	Art, Drama, Music, Dance (PE)

In S1 – S3, the pupils study the Curricular Areas at the Third and Fourth Levels of Curriculum for Excellence.

The following three areas embed certain skills across all learning in the curriculum and all subjects contribute to their development. These are:-

Literacy

Numeracy

Health & Wellbeing

Pupils will also enhance their learning via Interdisciplinary initiatives where different departments link together to deliver an aspect of the curriculum. This should ensure that learning can be transferred from one subject to another and will be more relevant for the pupils.

During all of this pupils should develop their **Skills for Learning, Life and Work** such as:-

Communications

Teamwork

Critical Thinking

Decision making

Cooperation

In S1 & S2, pupils mostly study at the Third Level of Curriculum for Excellence, while in S3, pupils will complete the Third and progress to the Fourth.

In S3, we also want to start preparing pupils for S4, the first of the main exam years, so Faculties will be looking closely at their S3 courses to ensure that there is greater depth, and relevant progress is made.

While all of the *Curricular Areas* are compulsory, in order to make your curriculum more *personal*, you will be given some choice *within* these areas in S3, in order to prepare you for exam choice in S4 and, eventually, S5 and S6.

Compulsory courses are:-

- Maths 4 periods per week
- English 4 periods per week
- French or Spanish 3 periods per week
- Personal and Social Education (PSE) 1 period per week
- Religious Education (RE) 2 periods per week
- Physical Education (PE) 2 periods per week

Choices. You must choose one from each Area below:-

- Science 3 periods per week
- Social Studies 3 periods per week
- Technology 3 periods per week
- Expressive Arts 3 periods per week

Personalisation:

- you may then choose an additional subject that you are likely to continue into S4 from any curricular area 3 periods per week
- you may then choose an additional subject to enrich your studies 2 periods per week

Your timetable will not be dissimilar to that in S2, however, you will have more periods of some of the subjects you enjoy the most.

Towards the end of S3, you will be asked to consider what subjects you wish to take forward to S4 as exam subjects. Hopefully, by then, you will have a clearer idea of what career you would like to follow and the necessary qualifications you will need.

During all of your courses you will be **Assessed** to:-

- Identify what you have achieved and let your parents/carers know
- Track your progress
- Help you decide on your next steps in learning
- Help us to support you better
- Help you decide what subjects to take in S4/5/6

At the end of S3 you will enter the **Senior Phase** and choose subjects to study towards qualifications.

The levels of the Scottish Qualifications available in school are:

Advanced Higher
Higher
National 5
National 4
National 3
National 2
National 1

Achievements in the wider sense are becoming more important in the competitive world of College, University and jobs. So Duke of Edinburgh, Voluntary Work, Charity Work, Leadership Awards, Citizenship Awards and the like, are more important than ever before.

These activities are great for enhancing the all-important skills and they look great on a CV.

Support

Support for Pupils and Senior Staff are at the heart of our support for you, and all are there to:-

- Help you choose courses appropriate to your needs and abilities
- Help you monitor how you are getting on with your courses
- Help you develop as an individual
- Give you guidance on careers

The Pupil Support Team can arrange to speak with you and your parents, so that all can contribute to the discussion.

Everyone has a difficulty learning something sometime!

All your teachers share the responsibility of supporting you at this time. However, some pupils need extra support, for example:-

- If you have been absent for a period of time and need to catch up
- If you lack confidence with reading, spelling, number work or something similar
- If you find difficulty planning and organising your class-work or homework

The Support for Learning Department is there to help and they may:-

- Support you in class or in the Department
- Consider reducing your number of options to give you a bit of extra time to concentrate on the others
- Apply for special consideration for you in the SQA exams

We all want you to do well and we will set you targets and monitor your progress to ensure that you do.

How can you support yourself?

- By keeping up your attendance and being on-time for school
- By doing your homework - this really enhances your learning and chance of success
- By dressing for work ie wearing School Uniform.
- Focus on your work.

All your hard work will be worth it in the end. The world of work is a competitive place.

Give yourself a sporting chance
Choose the right path



Personalisation and Choice

You already know why we are giving you choice, so, how do you make the best choices?

You **should** choose a subject because:-

- You like it
- You are good at it
- It could lead to a possible career in the future

Reasons **not** to choose a subject are:-

- Because you can't think of anything else to do
- Because that is what your friends are doing
- Because you like a particular teacher (there is no guarantee that you will have the same one)

Make your choices for positive reasons.

The structure that follows is constructed to enable you to make appropriate choices, while ensuring that you access all the Curricular Areas, as indicated by the Scottish Government.

**There are limits on choice, however.
We cannot guarantee that a course will run if:-**

- **There are not sufficient teachers to staff it**
- **Too few pupils choose it**

The school has a limited number of teachers and we have to weigh up the demands of all the other year groups as well.

Once all the pupils have made their choices, it is decided how many classes can run in the timetable. If some classes can't run because there are not enough pupils for the course, or not enough staff, some pupils may need to reconsider one of their choices.

Sometimes pupils start a course and very quickly find that it is not for them. Changes can be made if there is space in other courses, however we don't want this to be too far into the courses otherwise pupils will have missed too much work.

It is much better to get it right at the beginning so please listen to the advice given by the staff.



S3 Choice

A	B	C	D	E	F	G	H	I	J	K	L
4 ppw Maths	4 ppw English	3 ppw French Spanish	3 ppw Geography History Modern Studies	3 ppw Biology Chemistry Physics Environmental Science	3 ppw PE Drama Music Art	3 ppw Admin Business Management Computing Design + Manufacture	3 ppw PE Art Hospitality Computing History Chemistry	2 ppw Spanish Modern Studies Geography Physics Biology	1 P S E	2 R E	2 P E

S4 Choice

A	B		C	D	E	F	G		H	I	J
4 ppw Maths	4 ppw English		4 ppw Geography History Modern Studies	4 ppw Biology Chemistry Physics Environmental Science Practical Woodwork	4 ppw Art PE Drama Music Spanish French	4ppw Computing Admin Business Management Design + Manufacture Graphic Comm	4 ppw Spanish Chemistry PE Art Hospitality Computing History		1 pp w	2 pp w	2 pp w
									P S E	R E	P E

S5 Choice

	A	B	C	D	E		F	G
	6 ppw	6 ppw	6 ppw	6 ppw	6 ppw		1 pp w	2 pp w
ADVANCED HIGHER	Modern Studies History	Physics Biology	PE Maths	English Graphic Comm	Chemistry		P S E	R E
HIGHER	Maths Geog History Modern Studies Media Studies	English ESOL Biology Chemistry Physics	Art Maths Drama Music French Spanish PE	Computing English Admin Business Management Graphic Comm	Spanish Chemistry RMPS History PE College Neighbourhood School		P S E	R E
NAT 5 or NPA	Maths Practical Electronics Sports Leadership	English Travel & Tourism Practical Metalwork	Maths * People in Society	Hospitality ESOL	Cakecraft CGD **		P S E	R E

* Applications of Maths

** Computer Games Development

S3 Course Choice 2018

Pupils in S3 are entitled to continue with the Broad General Education (BGE) which ensures that all areas of the curriculum will be studied.

All pupils must study ***English, Maths, Modern Language, PE, Personal and Social Education and RE.***

A degree of personalisation and choice is permitted. Pupils must select one subject from each curricular area for study in S3.

Column D 3 periods per week	Column E 3 periods per week	Column F 3 periods per week	Column G 3 periods per week	Column H 3 periods per week	Column I Enrichment Column 2 periods per week
Geography	Biology	PE	Administration	Art	Spanish
History	Environmental	Drama	Business	Hospitality	Modern Studies
Modern Studies	Studies	Music	Management	Computing	Geography
	Chemistry	Art	Computing	History	Physics
	Physics		Design & Manufacture	Chemistry	Biology
<i>Alternative choice</i>	<i>Alternative choice</i>	<i>Alternative choice</i>	<i>Alternative choice</i>	<i>Alternative choice</i>	<i>Alternative choice</i>

Parental Signature:

Courses

Administration

What are the aims of the course?

The course aims to further develop your ICT skills and to build on the skills you have been learning in S1/2.

Administration focuses on the ways in which modern businesses use ICT to go about their daily work. The Administration course will also introduce you to how businesses get their employees to be more organised!

How is the course assessed?

The course will be assessed by end of unit tests and observation.

Homework

Homework will be given weekly. This will be based on the 'theory' parts of the course covered that week in class, for example Meetings and Health and Safety.



What will I be doing in class?

You will be working as a trainee for a business. You will be given an 'action plan' and you will be expected to treat the classroom like a real business.

You will be building on the ICT skills you used in S2, using Microsoft Software

What topics will I be studying?

THEORY

- The role of the Admin Assistant
- Working practices
- Office environment and security
- Health and safety legislations

PRACTICAL

- E-touch typing
- MS word/Excel/Access/Powerpoint
- Pupils will develop ICT skills to facilitate the transfer of ICT between classrooms and the world of work.

Pupils will work on tasks based on a simulation or real work place and be expected to select appropriate software to carry out tasks which support business and entrepreneurial activities.

Art & Design

Why Choose Art & Design?

Art & Design gives you the opportunity to:

- take part in design and expressive activities
- develop creative design & expressive skills
- appreciate social & cultural factors that influence design and expressive practice
- use a variety of art media and techniques developing work in 2D and 3D
- study design and expressive art techniques, genres and the impact of creative choices on society

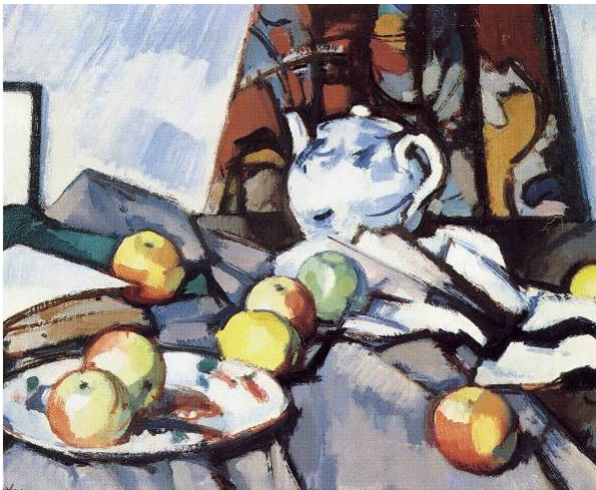

How is the course organised?

You will work on two main projects; a Design folio and an Expressive folio. For each you will produce a folder of practical and critical work. You will use a range of art media and techniques including paint, print and clay. In each unit you will study selected designers and artists gaining knowledge and understanding of the factors influencing them.

What kind of things will you be doing?

By the end of S3 you will have worked through a range of topics including:

- designers and design techniques
- factors influencing designers' work
- facts and opinions about designers' work
- produce creative design ideas using various design materials

- artists and techniques
- factors influencing artists' work
- facts and opinions about artists' work
- produce creative expressive work using various materials and techniques
- evaluate skills in the creative process
- produce an expressive art piece
- produce a graphic design
- reflect on the visual qualities and effectiveness of the outcomes

How are you assessed?

Assessment will be based on completed projects and pieces.

Homework will be based on research and investigative tasks as well as continuing to develop skills and techniques.

Career Opportunities

As well as being a desirable qualification for some college and university courses, Art & Design is essential for many careers and very useful for a great many more. Typical careers include:

- Architect
- Product designer
- Graphic designer
- Teacher
- Web page designer
- Make-up artist
- Fashion designer

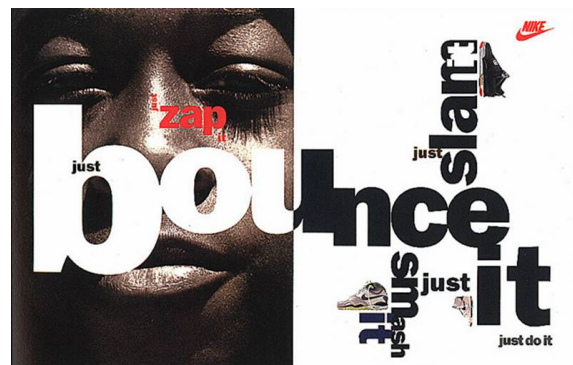

Biology

Why Choose Biology?

- Are you intrigued with the incredible variety of organisms that inhabit our planet?
- Can our global life-support system continue supporting an increasing human population?
- What lies ahead for the future of genetic engineering?
- What are clones and *transgenic* animals?



Biology is the scientific exploration of the vast and diverse world of living organisms; an exploration that will expand enormously in the 21st century. The study of Biology has an immediate relevance to our daily lives. It is important for everyone to develop an informed sense of how we may continue to fit into the complex ecology of our planet. Some of the greatest engineering feats of the future are likely to involve bioengineering projects and Biology.

Where Could A Biology Qualification Lead?

Biology is a relevant and often essential qualification in the following areas of work:

nursing; physiotherapy; radiotherapy; medicine; veterinary science; dentistry; laboratory technology; animal and plant breeding; psychology; pharmaceutical, horticultural, agricultural, environmental, water control, waste management, food, drink, and forestry industries. Biology is a useful science in many other careers

Biology is a good choice as it combines very well with both Physics and Chemistry.

How is the course organised?

The course will be organised into 3 broad, general units. They cover:

- Cell Biology
- Multicellular Organisms
- Life on Earth



Within the three units pupils will undertake the level 4 outcomes from the curriculum, providing them with the knowledge and skills necessary for studying National 4 or 5 Biology in S4.

What kind of things will you be doing?



Some of the Biology topics covered are human physiology, ecosystems, genetics, respiration, photosynthesis and enzymes. These taught through a variety of experiences such as lab work, field work, microscope work, computer simulations and research. You will learn collaboratively, working with others to develop your understanding. There will be opportunities to participate in educational excursions and visits e.g. the Royal Botanic Garden

How will you be assessed?

Assessment will be through a combination of ongoing assessment and end of unit tests and will be undertaken through teacher, self and peer assessment. Assessment will be undertaken in line with National Strategies, assessing both your understanding of Biology and the Skills for Learning, Life and Work.

Homework Requirements

Homework will be set weekly to help you develop your understanding. Homework will take a variety of forms, including research, problem solving questions, communication tasks and revision for tests.

Business Management

What are the aims of the course?

To develop your understanding of the current business world and to introduce you to how businesses are organised. You will learn how real businesses work and you use the Internet to look at these businesses in action.

How is the course assessed?

The course is assessed through end of unit assessment and ongoing observation.

Minimum Entry Requirements are:

A general interest in current affairs would be an advantage. **You will be expected to work in teams and take on extra work outside normal school hours.**

Have you the enthusiasm to work in business?

Have you got the skills to work in a team?

Homework

This will be per unit. Questions will be based on the theory covered in class that week. You will also be expected to watch the news or read a newspaper to keep up with current affairs.

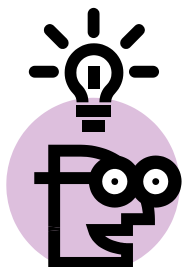

A-Bay.com

What topics will I be studying?

Some of the topics you will look at include:

- The role of operations
- Needs and wants
- Types of business
- Stakeholders
- Enterprise
- Business environment
- Success/failure of businesses
- Business ethics
- Finance
- Business and ICT
- Fair trade
- Human resources management
- The role of the Marketing Department

Will the course teach me how to run a business?

Yes and No!

The course will give you a flavour as to what different types of business do. There are a great number of skills you will learn in the course; for example problem solving and using your ICT skills.

During S3 you will be given the opportunity to **plan and run your own business**. Previous examples include; talent shows, selling footballs, santa hats, A Bay and Wrist Bands.

Related Careers

- Setting up your own business
- Marketing/HR/Finance manager
- Business Lawyer



Chemistry

Why Choose Chemistry?

The chemistry course in S3 is designed to introduce the ideas and concepts which will help you understand and make sense of the everyday importance of chemistry in the modern world.

Choosing to continue to study chemistry at National 5 level in S4 will lead to a solid grounding in the knowledge and skills you need to progress through the subject at Higher and Advanced Higher level.

You will be taught using experimental work which is an integral part of the course, helping to develop understanding and knowledge as well as your practical skills.

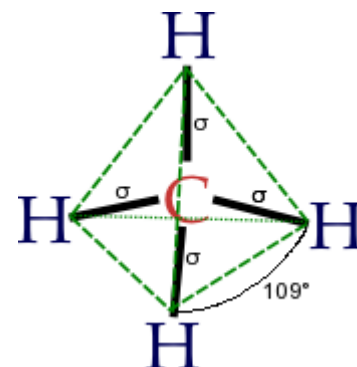

Where Could a Chemistry Qualification Lead?



Chemistry is the central science and a good understanding of chemistry will be a great advantage to you if you have an interest in a career in any science based field.

(Chemistry combines well with both Biology and Physics.)

Examples of careers involving Chemistry are forensic scientist, environmental scientist, physiotherapist, doctor, cosmetic scientist, food scientist, nurse, dentist, food scientist, nuclear scientist, vet, molecular biologist, chemical engineer, science teacher....

How is the course organised?

The course will be organised into 3 broad, general units. They cover:

- Chemical Changes and Structure
- Nature's Chemistry
- Chemistry in Society

Within the three units pupils will undertake the level 4 outcomes from the curriculum, providing them with the knowledge and skills necessary for studying National 4 or 5 Chemistry in S4.

What kind of things will you be doing?

You will develop skills and an awareness of ethical and environmental issues in a local and worldwide context and gain an understanding in how chemistry is involved in the cause, effect and resolution of these issues. Chemists will develop analytical skills through investigating new materials and energy sources and learn about the application of chemistry through everyday products such as cosmetics, fuel and food.



How will you be assessed?

Assessment will be through a combination of ongoing assessment and end of unit tests and will be undertaken through teacher, self and peer assessment. Assessment will be undertaken in line with National Strategies, assessing both your understanding of Chemistry and the Skills for Learning, Life and Work.

Homework Requirements

Homework will be set regularly to help you develop your understanding. Homework will take a variety of forms, including research, problem solving questions, communication tasks and revision for tests.

Computing

Why Choose Computing?

This course prepares young people for the challenges of rapidly changing digital technologies. In a practical and investigative way, it provides an understanding of the world through computational thinking and of computing technology. It also promotes problem solving by designing and developing computing solutions.

It develops a broad-based knowledge that establishes a foundation for further specialised study and careers including Robotics, Software Engineering, Medical Imaging, Web Design, Entertainment Technologies, Business Information Systems, Networking, Computer Gaming and Digital Forensics.

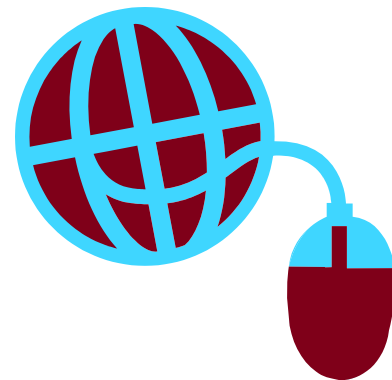

How is the course organised?

This practical course is organised in units with a blend of independent, paired and group work

What kind of things will you be doing?

- Graphics- Create complex images and animations using bitmap and vector graphics
- Programming- Design & develop your own programs using Scratch and LiveCode
- Digital Products- Create, collaborate and publish digital content online
- Digital Solutions- Build advanced websites using HTML and database systems
- Cyber Resilience- Understand how to protect new technologies and explore the impact of cybercrime
- Computer Systems- Explore complex real-life systems eg airline check-in
- Emerging Technologies- Explore Virtual Reality and Artificial Intelligence

How are you assessed?

An electronic portfolio is built up over each unit relating to practical evidence. Learner-led presentations and demonstrations will provide class discussion. A combination of peer and self assessment and ongoing observation will also be used. Progress checks will assess learners' knowledge and understanding.

Homework requirements

Each unit will have one or two set homework tasks.



Design & Manufacture

Why Choose Design & Manufacture?

The S3 course will give you an opportunity to develop more advanced designing and making skills. You will work on more complex and exciting design problems and learn more about commercial product design, industrial processes and their impact on society.

**think up
ideas**



How is the course organised?

You will work on a series of product design assignments. For each project you will produce a design folio then make the product. You will use a wider range of materials including wood, metal and plastics. In each project you will study design theory and gain knowledge of tools, materials, school workshop processes and industrial processes.

What kind of things will you be doing?

A typical project will involve:

- analysing a design brief
- researching ideas
- sketching initial ideas
- developing a final design
- planning the manufacture
- making the product or prototype
- testing and evaluating the design

Some lesson will involve:

- working independently on folio work
- working in groups when testing or evaluating
- using ICT for research
- displaying final work

How are you assessed?

At the end of S3, assessment will be based on

- quality of design folios
- design theory class tests
- quality of manufactured artefacts

Homework will mostly be focussed on design research, design theory and knowledge of tools, materials and processes.



**develop
solutions**

Career Opportunities

As well as teaching you useful life skills Design & Manufacture can lead to college and university courses. Design & Manufacture is essential for some careers and very useful for a great many more. Typical careers include:

- product design
- furniture design
- industrial design
- engineering
- technician services
- craft trades



**make or model
the solution(s)**

Drama

Why Choose Drama?

Drama is both educational and fun!



Drama has something for everyone. Drama teaches you a wide range of skills which are essential both in the workplace and in social situations. Drama can also be an interesting way of making new friends!

Drama isn't just for budding actors although some students have gone on to Drama college.

The course aims to build up your confidence and concentration by developing basic drama skills and using them to develop short pieces of drama.

Drama teaches you:-

- To present yourself effectively
- To talk confidently in front of others
- To speak clearly and fluently
- To cope with pressure
- To negotiate and be assertive
- To put yourself in other's shoes
- To evaluate and improve

How is the course organised?

The course is organised into units. Some units may last for only one lesson. Others might last for two or three weeks.

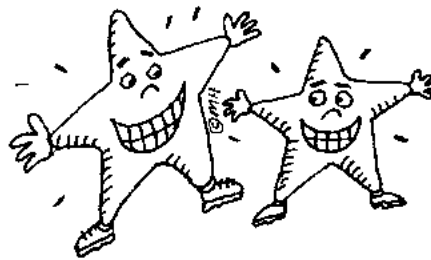

What kind of things will you be doing?

There is a wide range of interesting and fun activities.

Most of the course is made up of practical work with a small amount of written work. In some units you will learn basic acting skills and how to use the technical equipment. Other units will be theme based. You will be exploring a range of themes such as "Relationships", "Homeless" or "Ambition". Sometimes you might get to choose the theme!

You will be asked to create short plays and act in them or perhaps work the lighting or sound desks.

How are you assessed?

Your practical work will be assessed by your teacher who will observe you throughout the year. There will also be occasional short written assessments and you will be asked to assess yourself and others.



Homework Requirements



Homework will be set each week but will take a variety of forms.

Sometimes it might be learning some Drama words, researching a topic or answering some simple questions. You may have to learn some lines from a short script, or write your own short script.

Why Choose English?

Clear and effective communication skills are imperative for your success in learning, work and life. All careers require the skills that you will learn in your English classes. You will develop your skills of Reading, Writing, Listening and Talk in a variety of engaging ways.



How is the Course organised?

You will develop your skills through the broad general education course. Every S3 student will study:

- Creative writing
- Reading for UAE skills
- Discursive writing
- Talk and Listening skills
- Poetry
- A piece of “classic” literature

You will build on the skills that you develop throughout the year ensuring that you are progressing properly and preparing for the move to National exams.

What kind of things will you be doing?

You will do a variety of tasks for different purposes. You will be asked to work cooperatively in groups undertaking different roles in order to achieve the required outcome. This will be supported by solo and paired work. You can also expect to be asked to talk to the class on a topic chosen by you or your teacher.

In order to be successful you will reflect on your own skills and support your peers in their learning too. The teacher will also be giving you clear, achievable targets at every stage of the learning sequence to ensure that you are on track and challenged appropriately.

You will develop a Folio of work to demonstrate the development of your skills. This folio will be made up from a variety of the different experiences and outcomes that you have undertaken during the year.

You will be assessed by your teacher through ongoing observation of your class work, engagement with tasks and peers and an end of unit assessment where you get to demonstrate your acquired skills.

Homework requirements

The time that you spend on homework will vary depending on the area of the course. You should aim to develop your own skills at home through reading a variety of different text. This could be through novels, short stories, plays, poems, newspaper and magazine articles, comics, letters, websites, blogs, podcasts, films, manuals.

Your teacher may also set you work to enhance the learning that you have experienced in the class.

Welcome to English. We hope that you enjoy developing the skills of Reading, Writing, Listening and Talk knowing that you are best preparing yourself for a successful future beyond school.

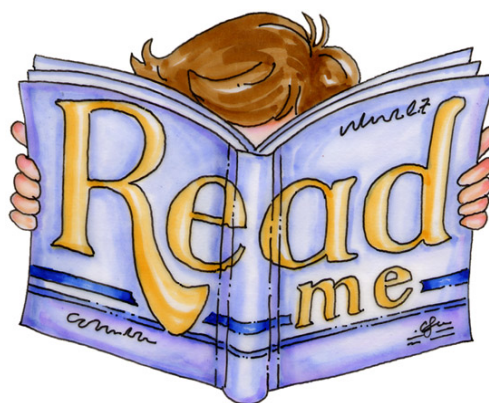

Environmental Science



Why Choose Environmental Science?

Science has a key role to play in ensuring that we have a sustainable environment, with resources that will last for generations and species that are protected and preserved. This will allow us, as a society, to continue to develop the materials and devices that have become part of our everyday lives whilst reducing the impact we have on the natural environment.

Our environment is changing fast; partly due to natural changes and partly due to human influence. The S3-4 Environmental Science course will help you to understand the issues discussed in the media and how they apply to your life.

Where Could An Environmental Science Qualification Lead?

Environmental Science provides a broad understanding of Science as a whole, bringing together aspects of Physics, Chemistry and Biology. This knowledge is useful in leading to careers such as in environmental management, ecology, farming, chemical manufacturing and energy production, in addition to many more. You would also be taught essential, transferable skills useful in all aspects of work.

How is the course organised?

The course will be organised into 3 broad, general units. They cover

- Living Environment
- Earth's Resources
- Sustainability



Over the two years pupils will undertake the level 3 and 4 outcomes from the curriculum, providing them with the knowledge and skills necessary for achieving National 3 or 4 Environmental Science or National 2 Science in the Environment.

What kind of things will you be doing?

Environmental Science is taught through a variety of experiences. You will have the opportunity to develop and monitor eco-systems, sample the local environment, undertake research, generate electricity, visit local industries, use practical techniques practiced in S1/2 to measure water quality and much more.



How will you be assessed?

Assessment will be primarily through continuous assessment through teacher, self and peer assessment. Assessment will be undertaken in line with National Strategies, assessing both your understanding of Environmental Science and the Skills for Learning, Life and Work.

Homework Requirements

Homework will be set regularly to help you develop your understanding. Homework will take a variety of forms, including research, problem solving questions, communication tasks and revision.

Geography

Why Choose Geography?

Geography inspires pupils to become global citizens by exploring their own place in the world, their values and responsibilities to other people, to the environment and to the sustainability of the planet. Geography equips you with a broad range of skills for learning, life and work such as teamwork, independent enquiry and creative thinking - all highly valued by colleges, universities and employers.

What you will study:

You will build on the topics covered in S1&2, continuing to look at the Human and Physical Environment as well as Environmental Issues. S3 units will include National Parks, weather, climate and glaciation, urban studies, population studies and farming.

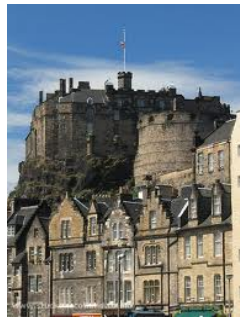

Methods of study will include:

Practical Skills – eg map reading; field-sketching; measuring & recording

ICT Activities – eg using GIS; research & analysis; presentations

Project & Group Work

Outdoor Learning & Fieldwork in the local area and further afield

Homework

You be assigned regular homework activities. These may include creative writing; gathering information; answering questions and revision.

Assessment

You will be regularly assessed in a variety of ways including - self and peer assessment; teacher observation; ongoing assessment of class work & project work.

Where can Geography take you?

Geography has a unique position in the curriculum; it fully embeds skills in literacy and numeracy and creates a bridge between the social and natural sciences.

Careers with Geography

- *Accountancy & Finance
- * Health & Education
- * Urban Planning
- * Law
- *Advertising & Market Research
- *Meteorology
- * Armed Forces
- * Retail Management
- * Engineering
- * Tourism & Sport
- * Primary & Secondary Teaching
- * Politics

... and lots more!

Graphic Communication

Why Choose Graphic Communication?

Graphic Communication gives you the opportunity to:

- develop more complex manual technical drawing skills
- develop more complex computer graphics skills
- produce a graphic presentation of a commercial product
- develop a knowledge of the use of graphic communication in industry



How is the course organised?

You will work through a series of drawing topics. At the end of each topic you will do a mini project demonstrating the use of the type of graphic in commerce or industry.

What kind of things will you be doing?

By the end of S3 you will have worked through a range of topics such as:

- orthographic views
- geometric drawing
- engineering & building drawing
- colour illustration techniques
- DTP



- Oblique, isometric & planometric views
- Perspective sketching
- 3D computer modelling
- 3D promotional graphics
- 2D and 3D computer aided drawing (CAD)
- Desk top publishing (DTP)
- Knowledge of use of CAD in industry



How is the Course assessed?

Assessment will be based on the completion of coursework drawings, class tests on graphics theory and the quality of project work.

Homework will mostly be focussed on design ideas for computer drawing projects and knowledge of graphics theory.

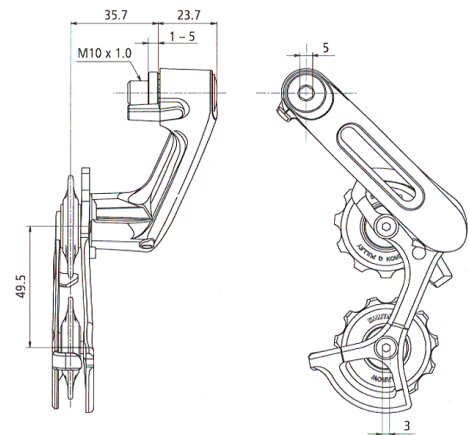

Career Opportunities

As well as being a desirable qualification for some college and university courses, Graphic Communication is essential for many careers and very useful for a great many more. Typical careers include:

- industrial draughting
- engineering
- graphic design
- architectural and building services
- product design
- interior design

Home Economics

Why Choose Home Economics?

Aims of course

To provide opportunities for learners to:

- Become familiar with a range of practical skills, food preparation techniques, cookery processes and textile construction skills.
- Follow flow charts/instructions to produce items; including dishes/meals and complimentary food promotion fabric textile display items, (e.g. Tartan goodie bags to promote Scottish Cuisine).
- Develop an awareness of the impact that the choice of ingredients has on health and wellbeing
- Develop an awareness of the importance of using local, seasonal, sustainable produce
- Understand and apply safe and hygienic routines
- Explore opportunities to design products using recycled materials

Description of the Course

The course consists of:

- Cookery Skills, Techniques and Processes: Food for the Seasons
- Skills, Techniques and Processes: Scottish Produce Promotion
- Understanding and Using Ingredients for Organisational Skills for Cooking

The main focus of these units are to give learners opportunities to develop practical related knowledge, understanding and skills, and to use them at home, in the wider community and, ultimately, in employment. Learners will produce food and textile items and become aware of issues affecting society, such as seasonality of produce, economic and sustainable food choices. Throughout the course learners will be provided opportunities to design and make items to mark calendar events, eg Christmas and Easter.



Future progression routes in the subject

In the senior phase, this course leads to Hospitality, (National 4 and 5 level) and Practical Cake Craft, (National 5 level).

Homework

Homework will be set throughout the course as:

- Research/assignments
- Theory tasks; short response answers

Practical tasks; practice and evaluations

Additional Information

The course contains a significant practical element therefore a keen interest in skill development is essential.

Although this is a very practical course there is an element of related theory/written work involved.

The course uses real-life hospitality contexts, which makes it relevant to the world of work.

The course develops a range of essential transferable skills which will stand students in good stead regardless of the career path they choose.

There is a **£45** charge for the course to contribute towards the purchase of consumable resources.

History

Why Choose History?

Are you interested in:

- Understanding world issues today?
- Learning more about your heritage?
- Discovering how your world has developed?
- Acquiring skills which will help you in a variety of careers?
- Studying a subject which can grow into an enjoyable life long interest?

**YES?
Then choose History!**



How is the course organised?

In S3 you will study 2 units of history. These will be the struggle for Civil Rights in America and the causes of World War One.



How will you learn?

You will examine evidence from the past using a variety of sources – written and visual.

You will learn how to judge how reliable and how valuable these sources are. You will form opinions, debate issues and listen to other points of view. You will investigate one or two topics in more detail.

You may have the opportunity to go on a 'Battlefields Experience'.

How are you assessed?

At the end of each topic you will be assessed on your knowledge and understanding of the topic and your ability to evaluate historical evidence. In addition you will be assessed through your teachers' ongoing observation and your input into the project activity.

Homework

You will be assigned regular homework activities. These may include creative writing; gathering information; answering questions and revision.



Mathematics

Introduction

All students will study Mathematics in S3. The course will build on the work done in S2. Students will continue to have the opportunity to experience the Curriculum for Excellence outcomes at Level 3 and 4.

Course Organisation

The course is organised into units each covering a number of experiences and outcomes from the three main areas of Mathematics:

- Number, Money and Measure
- Shape, Position and Movement
- Information Handling

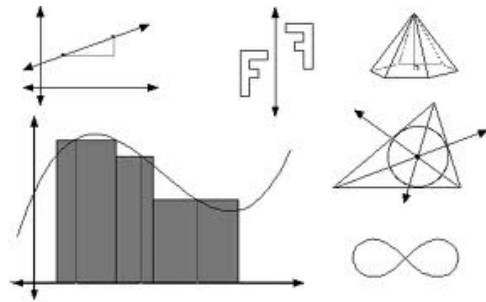

Assessment

There will be an assessment at the end of each unit. These assessments are good indicators of progress. They are used to provide feedback on areas of strength/weakness.

Homework

Students will be expected to do two main types of homework

- Formal; ink exercises. These will be checked by the teacher.
- Routine; revising for tests, completing class work, etc



Next Steps

In S4 students will follow NQ courses at Levels 3, 4 or 5 depending on their progress in S3.

Calculators

The SQA expects scientific calculators to be used in exams. Having your own scientific calculator is essential for Mathematics.



Modern Languages

Pupils entering S3 will continue to study Modern Languages. Pupils will have studied languages during the course of S1 and S2 and will be able to build on the skills they have already developed. They will be able to make a choice between French and Spanish.

Why study a Modern Language?

- New Scottish Government policy requires the study of languages
- As part of the European Union, Britain is in contact with partners and customers in Europe.
- Studying a Modern Language lets you understand people from another culture.
- More and more companies look for a qualification in Modern Languages.
- Many university courses require a Modern Language as part of the entry qualification.
- Related careers:



These are set in the context of:

- Society
- Learning
- Employability

What kind of things will you be doing?

- Topics**
- Leisure Time
 - Daily Routine
 - Descriptions
- Activities**
- Listening
 - Listening & Talking
 - Reading & Writing
 - Projects
 - ICT
 - Group Work

How are you assessed?

- Listening for information
- Listening & talking
- Reading
- Writing
- Project

Assessments in S3 are internal

Homework Requirements:

- Learning vocabulary & grammar
- Reading exercises
- Listening exercises
- Talking preparation

HAVING YOUR OWN DICTIONARY WILL BE HELPFUL!

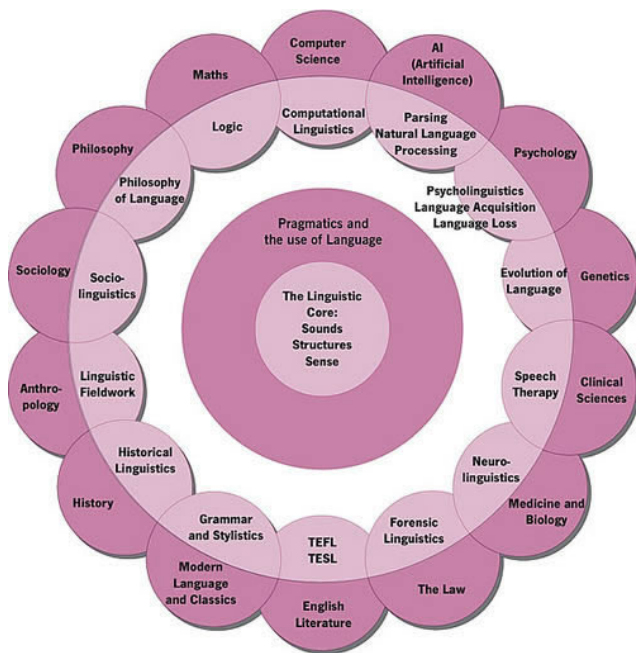

How is the course organised?

- The course is divided into units. Each unit covers a theme;
 - ❖ Leisure
 - ❖ Media/Technology
 - ❖ Describing People & Things
 - ❖ Holidays & Life Abroad
 - ❖ School & Future Plans



Modern Studies

Why Choose Modern Studies?

Modern Studies helps you to understand the most important issues in the world today. It helps you gather information about these issues, evaluate the information you have and most importantly, it helps you make your own mind up and come to your own conclusions about these issues. It is often said in Modern Studies that as long as you can support your argument with facts, you are never wrong! For example, what is your opinion on the war against terrorism?

Modern Studies is an **excellent qualification** for higher education and work. There are many university courses and careers that Modern Studies can lead to in Law, Medicine, Journalism, Accountancy and Finance, Politics, Sociology, Personnel, the Army/Navy/Air Force, Civil Service, Policy, Teaching, Social Work and many more.

Some of our most recent former Higher pupils are currently studying Law (Edinburgh University), International Relations (Edinburgh University), nursing (Queen Margaret University), education (Stirling University) and some are working for the NHS, Scottish Government, and training for the RAF.

How is the course organised?

There are three units which will enhance and extend the work of S1/2 and will also lay the foundations for the course in S4.

1. Political Issues in the UK

- Taking part in a democracy
- Actions of pressure groups

2. Social Issues in the UK

- Groups living in poverty eg families and the unemployed
- The Welfare State

3. International Issues in the USA

- Social and economic inequality
- Immigration
- Capitalism versus Communism
- Terrorism



What will I learn in Modern Studies?

The Modern Studies course teaches pupils the knowledge they need to understand social and political issues. It also involves the skills of evaluating sources, analysing information and making informed decisions. We also as a department emphasise and develop the literacy skills of pupils.

These transferable skills benefit pupils across the curriculum, for example with Close Reading or discursive writing in English.

How are you assessed?

- End of unit assessments
- Ongoing observations especially in group work
- Project work / research reports
- Peer assessment

Homework

Homework will be topic based with an emphasis on keeping up to date with current affairs.

Modern Studies in S4

In S4 the topics we cover are:

- Crime and Law
- American Politics
- UK Politics



S4 pupils take part in the Street Law programme run by the Law Society of Scotland. The programme complements our S4 Crime Unit and involves lawyers coming to the school to run active participatory sessions about the law and legal process.

Music

Why Choose Music?

Music is fun, challenging and satisfying!



Music teaches you to:

- Present yourself successfully
- Perform confidently in front of others
- Deal with pressure
- Work with others and contribute effectively
- Behave responsibly with equipment
- Evaluate and improve your performance

Music appeals to everyone in some way!

Music:

- Gives you a wide range of skills which are useful both in the workplace and in social situations
- Builds your confidence and self-esteem by developing your performing skills
- Is a great way of getting to know and work with other people
- Is a valuable addition to your CV and a pathway to other careers, eg Creative and Media work, Events Management, Sound Engineering, Primary Teaching, Special Needs Education etc. □



How is the course organised?

- The course is organised into the different elements of music – performing, composing and appreciating
- There are units of different lengths on different styles of music
- Performing and composing take place throughout the course

What kind of things will you be doing?

- There is a wide range of interesting and challenging activities
- Performing is at the heart of any expressive art, and most of the course is based on practical work. You will play 2 instruments (this can include singing), you will compose (and perhaps perform) your own music, and you will learn about a variety of musical styles and cultures.
- You may choose to develop your technical skills in Sound Engineering and Production – we have a fabulous studio and recording system
- You will work in pairs, groups and individually on performance, and your compositions will be produced using computer software.

How are you assessed?

Your practical work will be assessed by yourself, your class and your teacher, who will observe you throughout the year. There will also be end-of-unit tests and you will be asked to assess others.

Your compositions will form a folio of work, including scores and recordings, which will be assessed by your teacher, your class and yourself.

Homework

Most homework is in the form of instrumental (or vocal) practice, and this should be done daily.

There will be occasional written assignments on musical styles / genres.



Physical Education

In S3 you will receive three periods of core Physical Education per week.

The aims of core PE:

- We want you to develop a positive attitude towards physical exercise.
- We want you to understand the importance of a healthy lifestyle.
- We want you to develop good team-working skills.
- We want you to experience enjoyment of sport and physical activity, both now and in the future.

The core programme builds on the course from S1 and S2 and continues to focus on the outcomes and experiences of the 'Curriculum for Excellence'. However, in S3 you will be given more choice as to which activities you would like to participate in.

You will make a choice from a list of activities and the course will be based around the most popular choices. Each term you will choose an activity from a different category, these being:

- Team Activities
- Individual Pursuits
- Creative Activities
- Fitness and Health Related Activities
- Summer Activities



Assessment

You will be assessed continually throughout each activity block and decisions will be made in relation to how well you are achieving the outcomes of 'The Broad General Education'. Comments will also be made on your progress in performance, your participation rate and your effort.



A variety of assessment methods may be used such as teacher observation, self and peer evaluation, video analysis and live performances.

Homework

There is no specific written homework for core PE, although your teacher may give you a research task on occasion in order to help support the work you are doing in class. Your main homework in PE will be to become involved in regular physical activity outside of school.

Examination Courses in Physical Education

You will be given the opportunity to select an examination course in PE at the beginning of S4. However, you will be asked to identify this during your S3 course choices so that you can cover some extra work in S3 to help you prepare for your course in S4.



Possible Careers

Following courses in Physical Education can lead to a variety of careers such as Professional Sportsperson, PE teaching, Sports Coaching, Sports Physiotherapy, Sports Analyst, Leisure Management, Armed Forces, Police Service and the Fire Service.

Physics

Why Choose Physics?

Physics is a fascinating and enjoyable subject which is highly sought after by universities and employers. It is the Science which drives many advances that make our everyday lives comfortable and interesting – internet, mobile communication, animations, cinema, flight, medical physics and so on. Understanding Physics is made even easier when studied alongside either Chemistry or Biology.

There are a lot of discoveries still being made in Physics and various aspects of Physics are regularly discussed in the media. The S3 Physics course will help you to understand the issues discussed in the media and how they apply to your life.

Where Could A Physics Qualification Lead?

Physics is valuable for leading into a huge number of well paid professions. In addition to feeding into careers in technological research, engineering and physics, it is also very useful for further study in medicine, dentistry, chemistry, music, music technology and many more. You would also be taught essential skills and understanding necessary for work as an electrician or a mechanic.

How is the course organised?

The course will be organised into 3 broad, general units. They cover

- Electricity and Energy
- Waves and Radiation
- Dynamics and Space

Within those three units pupils will undertake the level 4 outcomes from the curriculum, providing them with the knowledge and skills necessary for studying National 4 or 5 Physics in S4.



What kind of things will you be doing?

Physics is taught through a variety of experiences. You will undertake experiments using both traditional and modern experimental techniques; you will learn collaboratively, working with others to develop your understanding; you will undertake research and computer simulations will be used to help you visualise what we cannot see. You may also have the opportunity to undertake visits to see Physics in use in industry.

How will you be assessed?

Assessment will be through a combination of ongoing assessment and end of unit tests and will be undertaken through teacher, self and peer assessment. Assessment will be undertaken in line with National Strategies, assessing both your understanding of Physics and the Skills for Learning, Life and Work.

Homework Requirements

Homework will be set weekly to help you develop your understanding. Homework will take a variety of forms, including research, problem solving questions, communication tasks and revision for tests.



Religious Education

Religious Education in the Catholic school is distinctive because of its focus on the faith development of young people within the context of a faith community. Its central purpose is to assist learners to make an informed, mature response to God's call to relationship.



A person matures in faith through a journey of unfolding encounter with God which takes place within the context of a person's total experience of life. One of the functions of Religious Education in a Catholic School is to provide learners with structured opportunities to experience this kind of encounter; with Jesus Christ at heart of the educational enterprise.

This Is Our Faith is the National Curriculum for Excellence syllabus for Roman Catholic schools. It provides core learning under eight strands of faith which young people experience from Primary 1 through to S6. In addition to the core curriculum there are opportunities for certification in Religious, Moral and Philosophical Studies in S5/S6. Religious Education is designed to engage pupils in an educational process which will:-

- Assist them to develop their knowledge and understanding of significant aspects of Catholic Christian faith, including an awareness of other Christian traditions and other world religions.
- Develop the skills of reflection, discernment, critical thinking and deciding how to act in accordance with an informed conscience in relation to matters of morality.
- Exemplify and foster the beliefs, values and practices which are compatible with a positive response to Christ's invitation to follow him.

In S3, pupils participate in the Youth and Philanthropy Initiative (YPI) which is an active citizenship programme that raises awareness amongst young people about philanthropy and their local community. Pupils are responsible for researching and representing a local charity with one team securing a £3000 YPI Grant for their charity. This is achieved through a unique programme of team work, research and competition.



Learners will also engage with *Called to Love* which is the Catholic Church's sex and relationships education programme for young people.

As well as academic and spiritual formation, there are opportunities for participation in the liturgical life of the Church within the school.

