

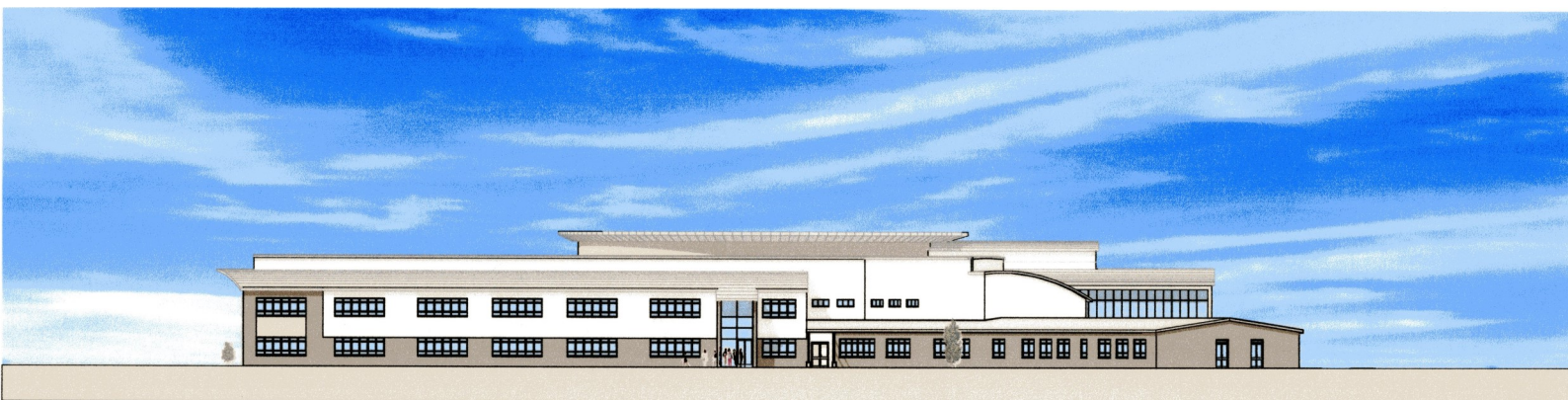

# A GUIDE TO S5/6 FOR STUDENTS AND PARENTS

2022—2023





St Augustine's R C High School  
Broomhouse Road  
Edinburgh  
EH12 9AD

Tel 0131 334 6801  
Fax 0131 334 7329  
E-mail [admin@st-augustines.edin.sch.uk](mailto:admin@st-augustines.edin.sch.uk)  
[www.st-augustines.edin.sch.uk](http://www.st-augustines.edin.sch.uk)  
St Augustine's HS—[@stahsnews](https://twitter.com/stahsnews) 

# Introduction

Dear Student

You now face a choice about whether to remain at school or move on. Unlike your parents' day, pupils nowadays have a number of different choices post National 4/5.

These are pathways:

- Pathway 1** – remain at school to study more National 5s, or progress to Higher courses or add breadth to your learning by undertaking a vocational course either here in school or at college. Pupils may also follow a Foundation Apprenticeship. These are usually reserved for those pupils who are academically able to follow a university course but follow an academic and business related course for two years in S5/S6, equivalent to Highers at University and in a business environment, and after 2 years equivalent to Advanced Highers.
- Pathway 2** – extended work experience through the JET + programme
- Pathway 3** – to continue more specific study at Edinburgh college
- Pathway 4** – undertake a Modern Apprenticeship. These allow you to earn while you learn, undertaking study at college and are often in vocational trades

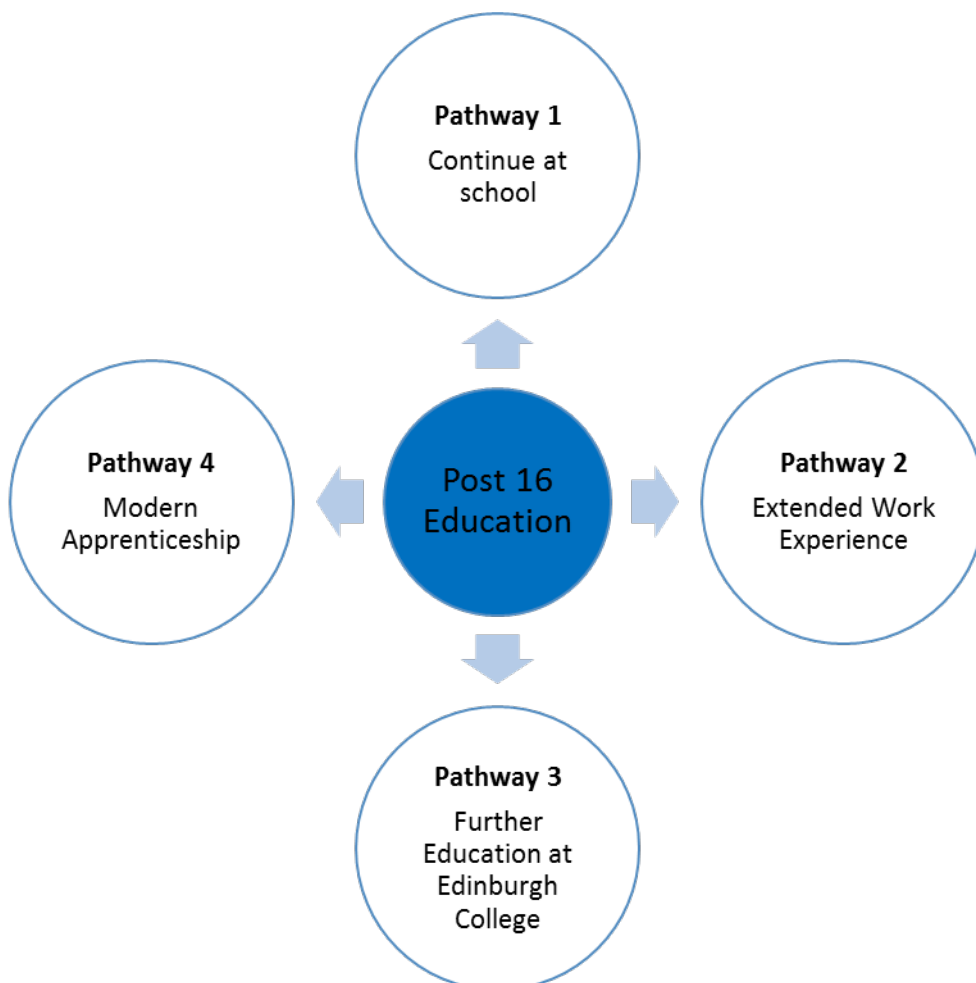

Please use this guide to help you decide:

- Which pathway is most appropriate for you
- Which course of study you wish to undertake

It is also a useful reference manual for S5/S6. You are given help in making your decision.

- Firstly this guide – this will start you thinking about the different possible pathways
- Secondly, there will be an extended assembly for S4 and S5 where the different pathways will be explained in full
- Lastly, your Pupil Support Leader will give you advice and guidance to make sure
  - ◆ You have planned carefully
  - ◆ Any questions you or your parents ask are answered
  - ◆ You are quite clear about what you are taking on

We all understand that the correct educational pathway is the “key” to great opportunities in future years.

For those pupils wishing to continue their studies at school, we will be looking for you to take part in the in the whole life of the school, to develop your leadership responsibilities and employability skill. The more you get involved in the whole life of the school, the more you will achieve and attain.

Yours faithfully

Mr A O’Doherty  
Head Teacher



# Contents

Introduction	3, 4
Contents	5
General Information	6
Which direction?	7
Pathway 1—Further study at school	8
Pathway 2—Foundation Apprenticeships	9
Pathway 3—College 16+	10
Pathway 4—Modern Apprenticeships	11, 12
Pathway 5—JET +	13
The Curriculum in S5/S6	14
Qualification Levels	15
What are Core Skills?	16
Aiming High	17
The Option Form	18, 19
Homework	20
How to be a Successful student	21
Careers	22
S5/S6 Student Contract & Application Form	23, 24
Your Entitlement Support	25
Financial Support: Education Maintenance Allowance	26
S6 is Different	27
S6 - Giving Service Back	28
S6 - Advanced Higher	29, 30
Course Information by Subject Department	31
Administration & IT	32
Art and Design	33
Biology	34
Business Education	35
Chemistry	36
Computing Science—National 5 & Higher	37
Creative Industries—National Certificate	38
Drama	39
Drama—NPA in Acting Performance	40
Early Learning and Childcare	41
English	42
ESOL	43
Enterprise & Employability	44
Geography	45
Graphic Communication	46
History	47
Hospitality: Practical Cookery	48
Human Biology	49
Mathematics & Applications of Mathematics	50
Media Studies	51
Modern Languages	52
Modern Studies	53
Music	54
Music Technology	55
People & Society—National 4	56
Photography	57
Physical Education	58
Physics	59
Practical Electronics	60
Practical Metalwork	61
Practical Woodwork	62
Religious, Moral and Philosophical Studies	63
Skills for Work: Laboratory Science	64
Skills for Work: Travel and Tourism	65
Jet Academy—Work based learning programme	66

The information in the **Guide** is accurate at the time of publication, January 2022. Major changes are unlikely to occur.



*General Information*

# Which direction?

You have good grades in Nat 5 exams and want to achieve some Highers or a Foundation apprenticeships so you can go to university or professional training

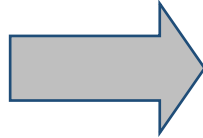

**Pathway 1**  
Continue at school

You have Nat 4/5s and would like to study subjects more related to your career perhaps with a practical element



**Pathway 2**  
Continue studies at Edinburgh College

You would like to work but continue studying for professional qualifications



**Pathway 3**  
Apply for a Modern Apprenticeship



You have completed your studies but are under 16



**Pathway 4**  
Extended work experience JET +



# Pathway 1

---

## Further Study at school

You may wish to stay on for further study in S5 and S6.

The choice often lies between full-time learning in school or college or with a business

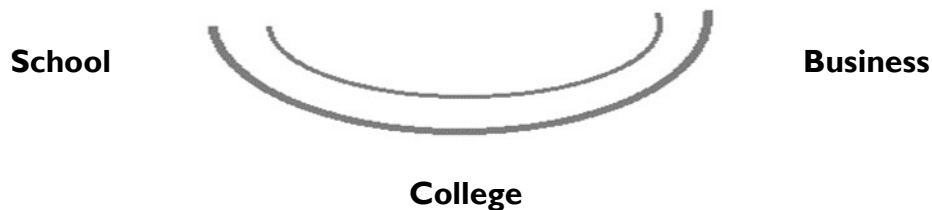

Many pupils opt to study for more National 5s, Highers and Advanced Highers at school. However, they can do this in combination with a course at college or a Foundation Apprenticeship.

Pupils who stay on at school beyond compulsory education are entering into a contract with the school.

From the school they can expect:

- ◇ A good range of courses to choose from
- ◇ Teaching and learning to gain academic qualifications
- ◇ Access to college or business opportunities
- ◇ Support with college or university applications
- ◇ The opportunity to take on leadership tasks to enhance their CV
- ◇ The development of employability skills
- ◇ Pastoral support for when times are challenging

We expect from our young adult pupils:

- ◇ Commitment to their studies
- ◇ Embracing the opportunity to add to their employability skills
- ◇ A good example to younger pupils
- ◇ Contribute to the pupil leadership of the school
- ◇ Representation of the school in the wider community

If this is your preferred Pathway, you can find details of the courses offered at the end of this booklet.

# Pathway 2

## Foundation Apprenticeships

*Get out of classroom and get a real taste of the world of work.*

A Foundation Apprenticeship is a work-based learning opportunity starting in S5 along with your Highers and Nat 5s ( apart from Financial services 1 yr ). The difference is, you spend time away from school, at college and with an employer. This way, you get real, practical work experience.

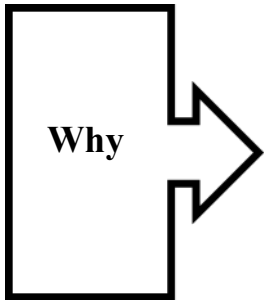

- A qualification that employers recognise and the skills you need to start a career in that industry
- The opportunity to work on real projects with an employer. Some of Scotland's biggest, best known organisations are involved, including Barclays, Network Rail and the NHS. Highly recommended for those looking for careers in Finance, Engineering or Health Care.
- Accepted as the equivalent of a Higher by 15 Scottish universities

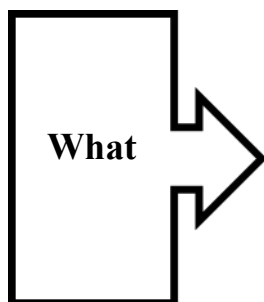

- Food and Drink Technology
- Business Skills
- Civil Engineering
- Engineering
- Financial Services
- Creative and Digital Media
- Scientific Technologies
- Social Services and Healthcare
- Software Development
- Accounting

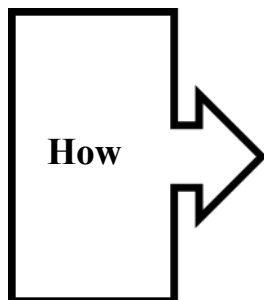

- 2 year study programme
- Time is spent out of school at college and with a local employer, and Foundation Apprenticeship is completed alongside school based qualifications, equivalent to Higher and Advanced Higher
- Year 1 at college, Year 2 work placement (Tues/Thurs pm)
- Choose in Column E
- Gain qualifications in NPA at level 6, and SVQ at level 6 equivalent to a Higher

# Pathway 3

## College 16+

### Transition into further education

This is a particularly good choice for pupils who do not intend to go to University or employment.

By S5/S6 you will have some idea of what you would like to do for a career. Following a course at college develops your knowledge of these career areas as well as the ability to develop other skills which make you more attractive to employers.

You may wish to attend college:

- In combination with your school studies eg College on Tuesday and Thursday afternoons
- On a full time basis, leaving school.

There is a wide range of vocational subjects on offer to complement existing studies. The majority of these courses are studied at college over 2 half days and with some courses there is an opportunity to follow on a full time basis.

There are also courses that begin in January of the coming year for Christmas Leavers. These are particularly useful for pupils who are in S5 but do not wish to go to University but into college or employment. Such courses include preparation for full time courses the following September or for particular employment areas such as dental nursing and construction or portfolio preparation for Art and Photography courses. Often these courses guarantee entry to the full time course in September.

**Apply now: [edinburghcollege.ac.uk](http://edinburghcollege.ac.uk)**

### Engineering

<b>Engineering Skills National 5</b> <span>Md F S</span>	No formal qualifications/requirements, however a minimum of 2 passes at SCQF Level 4 is preferred. Interest/understanding of Engineering.  *This course is also available as part of our Schools College Partnership (SCP) programme.
<b>Engineering Systems NC Access</b> <span>I Md F S</span>	2 passes at SCQF Level 4. You must complete a test/exam at interview.
<b>Engineering Systems (with Renewable Energy) HND</b> <span>Md F 7/8</span>	NC Engineering or Engineering Practice or NC Multi Discipline Engineering 2 Highers of English, Maths and Physics. You must complete a test/exam at interview.
<b>Energy and Environmental Engineering BEng</b> <span>Md F 8</span>	NC Engineering, Engineering Practice or Multi Discipline Engineering, 2 Higher pass in Maths or Physics plus one other. You must complete a test/exam at interview.

**Apply now: [edinburghcollege.ac.uk](http://edinburghcollege.ac.uk)**

<b>Coaching and Developing Sport HND</b> <span>G F 8</span>	Develop your confidence, interpersonal and leadership skills in two specialist sports, and enhance your knowledge and expertise in sports coaching, while gaining valuable real-life experience for your future career.  2 Higher passes at A-C level or equivalent. Adult learners with relevant employment/life experience will be considered. You must attend an information session. Places are conditional until a PVG check has been carried out.
<b>Fitness Health and Exercise HND</b> <span>MR S G F 8</span>	If you are looking to work in the sport and fitness industry, this course is for you. You will develop an in-depth understanding of the industry and gain valuable experience working with local groups. This course will prepare you for employment in fitness, health and allied occupations or articulation to university.  2 Higher passes in relevant subjects at B and C are required. Other relevant qualifications/experience will be considered. Adult learners with relevant life experience/skills will be considered for entry to this course. You must attend an information session.
<b>Sports Therapy HND</b> <span>S G F 8</span>	This practical course includes a strong theoretical component, providing you with the knowledge and skills required to work as a soft tissue therapist and provide clinical sports massage treatments. This course will prepare you for employment or articulation to university.  2 Highers at B or above, one in English and the second in a Science such as Human Biology. Relevant qualifications will be taken into account. Adult learners with relevant life experience/skills will be considered for entry to this course. You must attend an information session. Places are conditional until a PVG check has been carried out.
<b>Access to Coaching and Developing Sport HND</b> <span>G F 6</span>	If you are looking for a course to enhance your knowledge of coaching and developing sport to assist progression onto further study at HNC/D level, then this course is for you.  3 National 5s at 'C' or above, preferably to include English and/or a science subject. National 4 Biology would also be advantageous. You should currently be participating regularly in exercise and fitness activities. You must attend an information session. Places are conditional until a PVG check has been carried out.



# Pathway 4

## Modern Apprenticeships

### *Earn and Learn*

Each year, over 25,000 people start a Modern Apprenticeship – combining a qualification with on-the-job experience. This lets people work, learn and earn at the same time.

There are over 80 Modern Apprenticeship frameworks – from healthcare and financial services to construction and IT. These have been developed by sector skills councils, in consultation with their industry.

This means that Modern Apprentices can build valuable work experience from day one and gain an accredited qualification which is recognised by industry. They'll develop skills and expertise for their current and future jobs. Modern Apprenticeships are available at four different levels, some equivalent to a degree. Modern Apprenticeships are available for young people from 16-19 years old.

You can find most Modern Apprenticeships through the Website – The Edinburgh Guarantee. Your Skills Development Scotland Careers Adviser at school will be able to help you with your application.

Here are some examples:

### Business Administrator

#### **Salary:**

£17,642 per annum

#### **What might a day in this job look like?**

Business Administration roles vary but can include booking meetings, organising travel, using electronic filing and finance systems, dealing with internal and external stakeholders, managing diaries, ordering stationery, answering phones and responding to emails. Full training in all aspects of the job role and internal systems will be provided.

#### **What will I learn?**

You will work towards an SVQ Level 2 in Business and Administration. Training will be provided by an internal assessor who will work with and support you on a monthly basis. Time will be given to work on your qualification, which includes delivering two presentations.

## Vehicles Parts Person

### Salary:

£4.10 per hour

### What might a day in this job look like?

You will be supervised at all times on your jobs, so full support is always on hand. You will attend college for the first 2 years of the apprenticeship and then complete one final year in the Workshop, which will complete your qualification to be a fully Time-Served Parts Person.

### What will I learn?

- Level 3 Vocational Award in Motor Vehicle Parts Person
- Soft Skills (communication, teamwork, problem solving etc.)

## Chef

### Salary:

Starting salary £150 per week

### Work Environment:

You will be part of a team of 9 staff. You will be assigned a mentor who has gone through the apprenticeship programme here and knows exactly the challenges you are facing on a daily basis.

### What might a day in this job look like?

From cooking 5 course VIP dinners for celebrities like George Clooney and Arnold Schwarzenegger to catering for the thousands of visitors who attend the conferences, events and conventions held at the Edinburgh International Conference Centre, you will learn all aspects of working in a busy kitchen with experienced and qualified chefs.

### What will I learn?

You will work towards SVQ Level 2 and 3 in Food Preparation and Cooking through practical and theoretical assessment.

All your learning will be done on the job and you will also learn about team work, customer service and problem solving.

Find out more at:

<https://www.thegarantee.org/>

# Pathway 5

---

## JET +

*Job, Education and Training Programme*

*Extended Work Experience*

Some pupils have decided to leave school at the end of S4 but have not yet reached 16. (Christmas Leavers)

The JET Programme is a work-based learning programme. It is for pupils in the senior phase of High School.

If you are a Christmas leaver, you can have a full time extended work experience placement with an employer in the city. This is from August until Christmas instead of going to school.

You will take part in employability training sessions before starting your work experience.

Near the end of the programme, we will help and support you decide your next steps.

Placements can be found in a range of businesses and industries. These include catering, childcare, business administration, hair and beauty and some health and fitness organisations.

More information on the JET + programme will be available during May.



# The Curriculum in S5/S6

---

The curriculum for S5/S6 at St Augustine's differs from what you followed in the lower and middle school .

## **National Course**

- 160 hours duration
- Made up of 3 units plus course assessment
- Course assignment externally assessed by SQA
- Graded award, A, B, C and D
- *Course award only granted if you have passed 3 unit awards as well as the course assessment*

## **National Units**

- 40 hours duration
- Assessed internally by your teacher
- Using National Assessment Resources
- Internally verified by school staff
- Usually one opportunity only to resit unit
- Externally verified by SQA

And finally,

All you achieve throughout your school career will show on the *Scottish Qualifications Certificate*. Each year your new awards will be shown in bold.

The curriculum follows national guidelines. Your compulsory courses are:

- Personal and Social Education
- Religious Education

You choose five courses in S5 and four in S6. Although English is not compulsory in S5, we strongly recommend it. We have arranged the Option Form so you can maximise your opportunity to build on your strengths.

# Qualification Levels

Not all qualifications are achieved at school. All qualifications have different names. This depends on whether you sit them at school, college or University. However, they are all at equivalent Scottish Credit and Qualifications (SCQF) levels. Employers and Universities recruit people with different types of qualifications carrying particular Scottish Credit and Qualifications (SCQF) points. The Qualification Descriptors allow broad comparisons to be made between qualifications and allow learners, employers and the public in general to understand the range of skills and learning that should be achieved at each level.

SCQF LEVEL 4	<i>SQA National 4</i>	<i>NC National Certificate Level 4</i>	<i>NPA National Progression Award</i>	
SCQF LEVEL 5	<i>SQA National 5</i>	<i>NC National Certificate Level 5</i>	<i>NPA National Progression Award</i>	<i>Modern Apprenticeship</i>
SCQF LEVEL 6	<i>SQA Higher</i>	<i>NC National Certificate Level 6</i>	<i>PDA Professional Development Award</i>	<i>Foundation Apprenticeship</i>
SCQF LEVEL 7	<i>SQA Advanced Higher</i>	<i>HNC Higher National Certificate</i>		
SCQF LEVEL 8		<i>HND Higher National Diploma</i>		
SCQF LEVEL 9			<i>Bachelors Degree</i>	
SCQF LEVEL 10			<i>Honours Degree</i>	<i>Graduate Apprenticeship</i>

# Core Skills?

---

The Core Skills are:

## **Communication**

Essential whether spoken or written

- Helps you clarify your thoughts
- Enables you to relate to others
- Makes it possible for you to learn and to work

## **Numeracy**

- Helps you process, interpret and present quantifiable data
- Helps you understand, predict and solve problems

## **Problem Solving**

- Helps you to think critically
- To analyse situations
- To plan and organise work
- To reflect and make recommendations **for the future.**

## **Information Technology**

Is becoming increasingly useful in helping you:

- To obtain and analyse information
- To organise your ideas and thinking
- To communicate and work with others

## **Working with Others**

- Helps you focus on ways of working together towards shared goals.

## **How Do You Gather Core Skills?**

Unbeknown to you, you will have gained automatic certification for most if not all of the core skills because you followed National courses in S4. For example, Communication is embedded in National English, Numeracy in National Mathematics.

You can gain core skills at different levels up to Higher, often as a result of gaining National Qualifications.



# Aiming High

---

The key to achieving your goals in S5/S6 is aiming high

- Aim High • take pride in yourself
- Aim High • set yourself a challenge
- Aim High • surprise yourself
- Aim High • have something to show for your year
- Aim High • make your school work your top priority

We advise you to choose a course because

- ✓ You liked it
- ✓ You were good at it
- ✓ It fitted in with your career plans

Now we can help you be more sophisticated in choosing your courses.

Your Pupil Support Teacher has information to help you and your parents choose the appropriate courses.

## ***Be Aware Subjects are Different***

National research tells us that students achieve higher success rates in some subjects than in others. If you are academically successful and hard working then this really doesn't affect you. However, if your achievements to date are more modest it pays to think about the relative ease or difficulty of different courses.

Of course if you want to follow a course *either* because you need it for career purposes *or* because you really enjoy it, then you will be motivated to succeed, regardless!

# The Option Form

## The Form Itself

You must choose five courses in S5 and four courses when you move on to S6.

If you plan to follow three courses at Advanced Higher this minimum *may* be relaxed to three courses to allow time for the additional personal research involved.

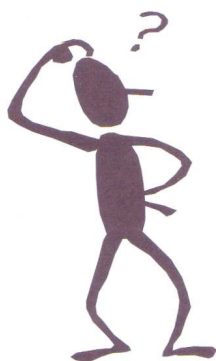

## Are there Limits on Choice?

Yes there are.

**Firstly we cannot commit ourselves to run a course if there is not a teacher to staff it.** You might wonder why we offer such a course at all!

This situation only arises when we have a very large demand for a course. That might mean we need more hours of teaching than the present teachers have available.

In such cases, regrettably, some students to need to choose another course.

**Secondly we cannot commit ourselves to run a course if too few students choose it.**

As a school we have a finite number of teachers. Your teachers have to cover the demand for courses in S1 to S4 as well.

When we consider whether a course is to run, we set your needs against those of other year groups.

*Our aim is to give you the choices you want as far as is possible. It suits us both to see you start out on the courses of your choice.*

However, there are limits. It is better that we are upfront about them.

## Are There Any Other Choices?

St Augustine's has formed strong links with neighbouring High Schools and Edinburgh College.

If you

- have a clash of subjects
- find your choice is not running
- want to try something completely new

then your Pupil Support Teacher will be able to advise.

In our school neighbourhood, and at Edinburgh College, courses may be available that we cannot offer in our own school due to lack of numbers.

It is more convenient to follow your courses here. However, it is also good to learn how to fit in to other classes and meet other students— good preparation for life.

## Can I Change My Choices?

We really would rather you didn't.

Once all students have made their choices, the Head Teacher, decides how many classes will run in each course.

Sometimes there are spare spaces left. However: we cannot guarantee there will be spaces. Better then to make good choices right from the start to make sure of a place on the courses you want!

There is a second reason why we want you to choose well from the start. If you ask to change you are joining a course where you have already missed work. There will be catching up to do.

# S† Augustine's RC High School

## S5/6 Options Sheet Session 2022/2023

All pupils in S5 have two periods of RE and a period of PSE.

Pupils in S6 have a period of PSE, a period of RE and a period of Citizenship where they choose between working to achieve the SQA NPA in Leadership or the Pope Benedict CARITAS award.

	Col A	Col B	Col C	Col D	Col E	Col F	Col G	Col H
Level 5	Practical Cookery	Practical Woodwork	Employability & Enterprise	Practical Metalwork	Applications of Maths	PSE	RE	RE (S5)
	Laboratory Science	Travel & Tourism	Media	Graphic Communication	Practical Electronics			
	Childcare		Music Technology	People and Society	Practical Cookery			
Level 5 and Level 6 combined Some classes will be Level 6 only	Maths	English	Maths	English	COLLEGE	RE	PSE	CARITAS (S6)
	Human Biology	Biology	Physics	Art	Biology			
	Drama	Chemistry	Geography	History	Chemistry			
	NPA Acting & Performance	Computing Science	History	Computing Science	Sports Leadership			
	Music	Physical Education	Modern Studies	Administration	Spanish			
	Physical Education		Creative Industries	Business Management	RMPS			
	French		Spanish	People in Society				
Level 7	Maths	Chemistry	Physics	English	Biology			
	Drama	Physical Education	Modern Studies					SQA Leadership (S6)

Foundation Apprenticeships can be taken over 1 or 2 years and are available in the following areas:-

- Accounting
- Finance
- Technology
- Civil Engineering
- Creative Industries
- Business
- Food & Drink
- Engineering
- Science Technology
- Health and Social care

# Homework

## **Why Homework?**

**You** know and **we** know that you will only make the most of the senior school if you are prepared to do your homework.

Any worthwhile goal takes effort. Your goal is to achieve the best results you can by the end of the year.

You need to do homework regularly so that you can understand and apply your learning.

## **What Is Homework Anyway?**

Homework can take many forms:

- Completing work after class
- Preparing for your next lesson
- A short task
- A more ambitious project
- Revision of coursework
- Practice for tests and exams



## **Help With Homework**

You will be issued, as always, with a Homework Diary. Use it well to keep track of when your homework is due.

Ask your family for support. Ask them to leave you in peace and quiet when you have homework to do. Make sure, then, that you *do* your homework!

Your teachers will be only too happy to give you further help if you are not sure what to do. Of course, your teacher will not accept “I didn't know what to do” as an excuse for not handing homework in on time! (This usually means “I left it to the last minute so ran out of time to do it”!!!)

For a variety of reasons you might find it is not too easy to get the peace and quiet you need at home. You can use the school library as a place to work at lunchtime, or after school. Some teachers also run informal arrangements at lunchtime.

If you have difficulties with homework the person to discuss these with is your Guidance Teacher.

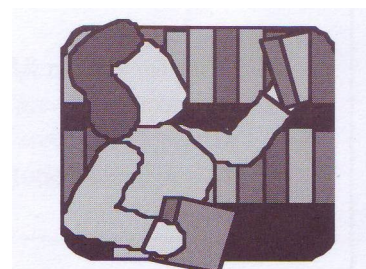

## **Helpful Hints For Doing Your Homework**

- Get into a regular routine and time of day for doing your homework
- Use your Homework Diary to check when homework is due.
- Do the “hard” bits first. If you leave them to last you will never get round to them
- Give yourself a fifteen minute break after forty five minutes. Then remember to go back to work!
- Read it over when you have finished . Does it have a date, title? Is it neat?

# How to Be A Successful Student

---

## **Getting Ready**

- Work out what you have to revise. Is it just one unit, or a full year's work? Do you have to include work from earlier sessions?
- Sort out your material neatly. Tidy up your notes. Label them clearly.
- Make a weekly plan for homework and revision . Homework comes first!
- Plan at least 20 hours work per week in the countdown to the prelims and the May exams.

## **Studying**

- Work for at least 15 minutes at a time. Anything less simply isn't worth it.
- Plan your breaks. Don't work for more than an hour without a break.
- Start early while your mind is fresh.
- Do the hard bits first, or you will never get round to them!
- Set yourself clear start and finish times.
- Leave time to wind down and relax before you go to bed.

# Careers

## Our Goals

More than ever before you will aim in S5/S6 to gain the knowledge, the skills, the qualifications and the experiences which will be your passport to life beyond school.

### You Want

- to know where to find out about jobs
- to know what qualifications you need
- help with job seeking skills

### We Want

- to make sure your ambitions are realistic
- to widen your vision
- to advance your job seeking skills
- to give you access to a comprehensive careers network.

#### People

Pupil Support Team  
Careers Adviser

#### Courses

Personal and Social Education

#### In School Resources

Careers Library  
Careers Clinic

#### Careers Education

#### Out of School Resources

Open days  
Careers Conventions  
Career Conferences  
Work Experience

**Mr Des Foley** is the Careers Adviser attached to St Augustine's RC High School. He is available:

- at Parents' Evenings
- on Tuesday's in the Working Together Base
- for individual careers interviews

Mr Foley is based at:  
Skills Development Scotland  
Apex House  
Haymarket Terrace  
Edinburgh, EH3 8EG  
Tel: 0131 313 6114  
Fax: 0131 313 0093

E-mail: [desmond.foley@careers-scotland.org.uk](mailto:desmond.foley@careers-scotland.org.uk)  
You and your parents are always welcome to telephone his office to arrange an appointment.



# S5/S6 Student Contract

The “Why Stay On” section of the Guide emphasised how it is an important choice to stay on for S5 & S6 at St Augustine’s. The curriculum is set out to maximise your chances of success– as is the advice you will receive on coursing. The Guide goes on to outline how you need to support yourself and how we support you. We look for commitments in return. As such, we are asking all students who wish to return to S5/6 to complete an application form detailing what they can offer to the school. When your son or daughter brings it home, we would ask you to discuss it with them and sign the declaration on the back.

Declaration:

*If I am accepted into the senior school at St Augustine’s next session I agree to abide by the following in order to maximise my potential and chances of success. I understand that if these conditions are not met then discussions with myself, the school and my parents/carers regarding my future placement may result in my school place being withdrawn. It will also stop payment of any EMA which I may receive.*

*I agree to:*

- *Maintain an attendance of 90% or above*
- *Arrive at school punctually – no more than one late a week or 5 lates in a term*
- *Maintain a positive attitude and workrate in all my classes for the whole year*
- *Attend all classes and complete all NABs, homework and classwork for the whole year*
- *Wear full school uniform including blazer and tie*
- *Participate fully in all duties or committees which I sign up to for the whole year*
- *Respect the rules and values of St Augustine’s High School*
- *I will remain in school at all times during the day even if I have a study period (in S6)*

Signature:

Date:

Parental Signature:

Pupil Support Leader Signature:

**DATA PROTECTION ACT 1998:**

**St Augustine’s will share the contents of this application form with Skills Development Scotland. Personal info held by Skills Development Scotland will be used to provide career management services and to monitor the progress of individuals**

# Senior School Application Form

St Augustine's High School  
Senior School Application Form – S5 or S6  
Session 2014- 2015

Name:	Date of Birth:	Age:
Address:	E-mail:	
Class: Phone:		
Mobile:		
<b>S4 QUALIFICATIONS</b>		
Subject	Level	Predicted Grade (Prelim result)
English		
Maths		
<b>S5 QUALIFICATIONS – If appropriate</b>		
Subject	Level	Predicted Grade (Prelim result)
<b>SUBJECTS I HOPE TO STUDY IN S5 or in S6</b>		
<b>LEAVING SCHOOL</b>		
What to you plan to do when you leave school?		
College	Employment	Gap Year
University	Training	
<b>ADDITIONAL INFORMATION</b>		
Do you have any health or disability issues which may affect your career?		
Yes:	No:	Don't wish to say:
Will you receive an EMA? _____		

**PERSONAL STATEMENT**

What skills & qualities have you got which will be useful in fifth or sixth year? \_\_\_\_\_

\_\_\_\_\_

\_\_\_\_\_

\_\_\_\_\_

Why do you want to return for a fifth or sixth year? \_\_\_\_\_

\_\_\_\_\_

\_\_\_\_\_

What else can you contribute to the whole school community? \_\_\_\_\_

\_\_\_\_\_

\_\_\_\_\_

**REFERENCE (If your guidance teacher had to write a reference for you, what do you think it would say?)**

Attendance: \_\_\_\_\_

Punctuality: \_\_\_\_\_

Attitude to work: \_\_\_\_\_

Relationship with others (staff and peers): \_\_\_\_\_

Any other comments: \_\_\_\_\_

\_\_\_\_\_

\_\_\_\_\_

Once you have completed this form, please return it to your Pupil Support Leader for Signature.

# Your Entitlement to Support

As you enter the senior school you are entitled to quality support. That support will come from a variety of sources

- your subject teachers
- your Pupil Support teacher
- your careers officer
- your parents

<b>When</b>	<b>Entitlement</b>	<b>How</b>
When you are considering S5/S6	Help with planning what to study	<ul style="list-style-type: none"> <li>• course information</li> <li>• awareness of your interests, qualities, abilities, attainment and achievements</li> </ul>
When you are starting your courses	Information on expectations and goals	<ul style="list-style-type: none"> <li>• an induction programme</li> <li>• negotiation of personal targets</li> </ul>
As you are following your programme of study	Ongoing support for your progress	<ul style="list-style-type: none"> <li>• regular feedback on your progress</li> <li>• formal opportunities to review, revise plans and targets</li> <li>• support to achieve these</li> </ul>
As you think of what to do after S5/S6	Help to make sure what you choose to do after S5/S6 builds on what you have done in S5/S6	<ul style="list-style-type: none"> <li>• help with reviewing progress</li> <li>• information on choices after S5/S6</li> <li>• help in developing an action plan for the future</li> </ul>

At St Augustine's we have an excellent team of Pupil Support Teachers. Their aim is to assist you in achieving all you can in S5/S6.

Much effort and energy goes into this first stage of helping you choose wisely and well.

However: it is as important that you keep your high expectations of yourself active throughout S5/S6.

With help from your subject teachers, your Pupil Support Teacher will help you keep an overview of your progress.

# *Financial Support: Educational Maintenance Allowance*

---

This is a government initiative which supports students and their families and is dependant on the total amount of money coming into the household.

It consists of a weekly payment, paid directly to young people, who stay on in further education after they reach the statutory leaving age.

Application forms are available from the City of Edinburgh Council or the school.

The council will notify all applicants about whether or not they are entitled to an EMA.

Payments are made directly into each student's bank account and are only made to those students who have satisfied attendance and punctuality requirements and have made satisfactory progress on their chosen courses.

# S6 Is Different

St Augustine's RC High School has many, many strengths, but one of its greatest is its Sixth Year students. Sixth Year students have an immediate impact on any visitor. Sixth Year students have a high profile around and about the school. Sixth Year students play an invaluable role in maintaining and developing the community spirit of St Augustine's.

Actually, it is very easy for Sixth Year to be a big disappointment!

- It is quite easy for you to find Sixth Year a bit of an anticlimax after the intense studying you put in to achieving your Highers in S5.
- The absence of a full timetable, and with that a regular work routine, can allow good study habits to fade.
- You may find repeating some courses a bit of a bore.
- Sometimes S6 feel teachers are more interested in S5 Higher students who are tackling courses for the first time.
- You may miss many of the friends who came through school with you until Sixth Year.
- Some of your fellow Sixth Year students will spend time travelling to and studying in neighbouring high schools or at college. You may miss them too.

It all sounds potentially very depressing— yet Sixth Year can be a very rewarding year. How?

**Firstly: we keep you busy on the courses which lead you towards national awards.** All option courses have six periods a week. You are required to follow a minimum of four. Add your two periods for Personal and Social Education and Religious and Moral Education and that leaves six periods for study.

**Secondly: we capitalise on your many, many talents.** At St Augustine's there are not enough hours in the day nor enough people on our staff, to do all that we would want, to make this the best of all possible schools. That's why we turn to you for help.

You have some time, You have benefited from five years as part of our community. You know our values, the things we stand for. And, you have talent, knowledge, skills, ideas and contacts.

You will also be timetabled for 1 period of mentoring/citizenship/leadership, where each week, a member of staff will “check-in” with you to see if you are on track with your studying and to see how you are contributing to the school community. Good for the CV!

# S6 - Giving Service Back

All Sixth Year students are expected to be of service to the full school community. Why?

- we all benefit from the positive ethos you create through service
- you discover qualities you never knew you had
- you gain in confidence
- you develop a collective responsibility for school
- and, you can enjoy it as well.

## How Can You Be of Service?

Sixth Year students contribute to a rota of **dinner duty** helpers. You know ( probably because you did it yourself when you were younger) that not all pupils are deferential, especially when they are hungry! Yet, this shared task is probably one of the most important ways you are of help.

On the other hand, Sixth Year help to organise and **run events** for younger year groups. Apart from the need to resist pleas for tickets “on credit” these are usually fun events and much appreciated by younger year groups.

Over the past years Sixth Year (and some Fifth Year) students have taken on the mantle of **buddies** to the new SI, both when they come up for their visit in June, but also throughout their First year. This developing role is very much appreciated by our new intake and their parents.

Many Sixth year students can get involved in collecting money for the various **charities** that we support. Hidden talents often emerge when finding new ways to collect money!

Sixth Year students also contribute directly to the learning process for younger pupils. Under the tutelage of the Principal Teacher Support for Learning, Sixth Year students can assist slow readers with **paired reading** or by **peer tutoring** in class.

These are all ways in which Sixth Year students have given something back to the school community. However, you are free to contribute your own ideas of ways we can capitalise on your talents and experience.

Our key aim is to ensure that Sixth Year is a fulfilling and successful climax to your time at St Augustine’s RC High School.

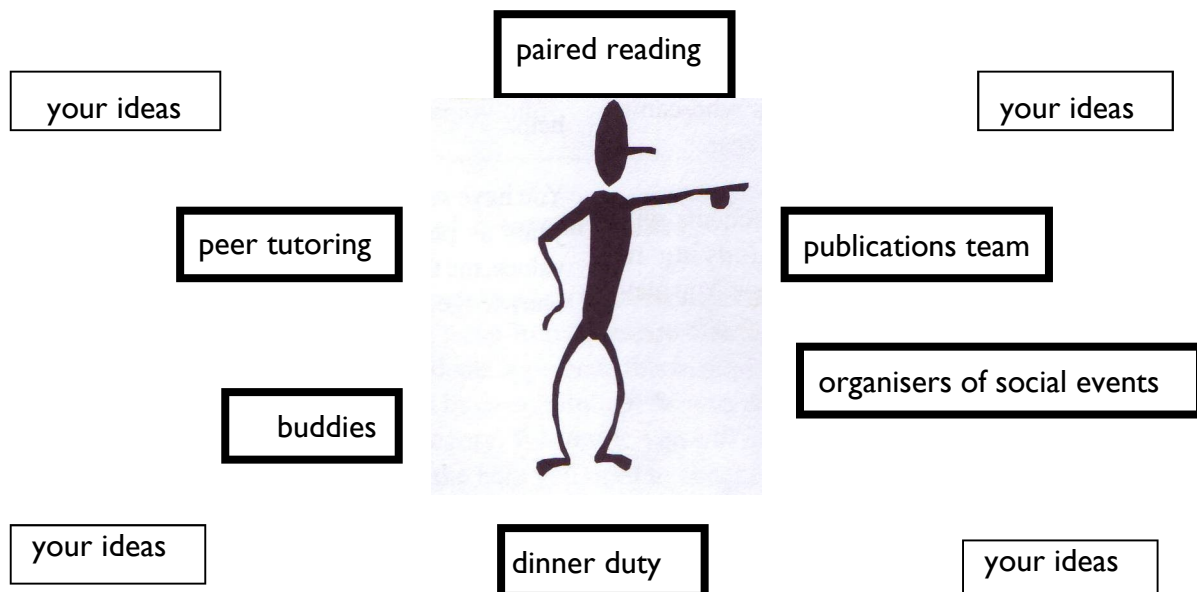



# S6 - Advanced Higher

The City of Edinburgh Council are currently reviewing the provision of Advanced Higher courses in schools and are likely to move to consortium arrangements where different schools offer different Advanced Highers. While this may result in not all Advanced Higher courses being offered at St Augustine's, courses will be available at other schools/centres.

Advanced Higher courses lead to the highest qualification available in secondary school. The entry qualification is the same for them all: a minimum B award at Higher Grade.

The emphasis is on extensive individual research. If you want to follow an Advanced Higher course you must be very committed and very organised. In particular be prepared to devote far more than your timetabled periods to your Advanced Higher work.

We offer a range of Advanced Higher courses at St Augustine's. However, you may find that you need to travel to a neighbouring high school to follow your course. Only a minority of students follow Advanced Higher courses so we cannot guarantee that courses will run here.

The Advanced Higher courses outlined below are the ones which run most commonly here at St Augustine's.

<b>Course</b>	<b>Description</b>
<b>Biology</b>	<ul style="list-style-type: none"> <li>• <i>Entry Point:</i> A or B in Higher Biology and preferably Higher Mathematics</li> <li>• <i>Theory units</i>—Cells &amp; Proteins and Organisms &amp; Evolution</li> <li>• <i>One Investigation</i></li> </ul>
<b>Chemistry</b>	<ul style="list-style-type: none"> <li>• <i>Entry Point:</i> A or B in Higher Chemistry and preferably Higher Maths</li> <li>• <i>Theory</i>—Inorganic Chemistry, Physical Chemistry, Organic Chemistry and Instrument Analysis</li> <li>• <i>Practical</i>—prescribed experiments to be carried out</li> <li>• <i>Investigation Project</i>— independent, practical study and report</li> </ul>
<b>Computing</b>	<ul style="list-style-type: none"> <li>• <i>Entry Point:</i> Higher Computing</li> </ul> <p>The course has four areas of study:</p> <ul style="list-style-type: none"> <li>• Software design and development</li> <li>• Computer systems</li> <li>• Database design and development</li> <li>• Web design &amp; development</li> </ul> <p>Assessment (to be finally confirmed by SQA)</p> <ul style="list-style-type: none"> <li>• External assessment 50%</li> <li>• Course assignment 50%</li> </ul>
<b>English</b>	<ul style="list-style-type: none"> <li>• Course Work</li> <li>• <i>Literature</i>— study of a selection of literature</li> <li>• <i>Creative writing</i>— folio of 2 pieces from a selection of genres</li> <li>• <i>Dissertation</i>— of 2,500 words</li> </ul> <p>Exam</p> <ul style="list-style-type: none"> <li>• <i>One essay</i>— written in timed conditions (on literature)</li> <li>• <i>Textual Analysis</i> – analysis of an unseen text</li> </ul>
<b>History</b>	<p><i>An in depth study of The Spanish Civil war 1931-39 includes:</i></p> <ul style="list-style-type: none"> <li>• Why the monarchy was replaced by a Republic in 1931</li> <li>• The problems facing the Republican Governments in 1931-36</li> <li>• The failure of the military coup of 1936 and how it developed into a prolonged civil war</li> <li>• The rise of Franco</li> <li>• The reason for the Nationalist's victory in 1939</li> <li>• <i>A Dissertation</i>— 4-5000 words</li> </ul>
<b>Mathematics</b>	<ul style="list-style-type: none"> <li>• The course extends to knowledge of Algebra, Geometry, Calculus and Trigonometry gained at Higher.</li> <li>• 3 end of unit tests</li> </ul> <p>Assessment—two papers. Non-calculator and calculator paper. Question paper 1 (non-calculator) 35 marks, 1 hour. Question paper 2 (calculator) 80 marks, 2 hours 30 mins.</p>

# S6 - Advanced Higher cont'd

<b>Course</b>	<b>Description</b>
<b>Modern Studies</b>	<ul style="list-style-type: none"> <li>• <i>Study topic</i>– Law and Order consisting of three units</li> <li>• <i>Unit 1</i>– The Causes and Effects of Crime in the UK</li> <li>• <i>Unit 2</i>– The Penal System</li> <li>• <i>Unit 3</i>– Research Methods</li> <li>• <i>A Dissertation</i>– 4,500 words</li> </ul>
<b>Physical Education</b>	<ul style="list-style-type: none"> <li>• <i>Unit 1</i> - Performance Skills</li> <li>• <i>Unit 2</i> - Factors Impacting on Performance</li> <li>• <i>Course Assessment</i>:- <ul style="list-style-type: none"> <li>One-off performance: 30 marks</li> <li>Project: 70 marks</li> </ul> </li> <li>• <i>Entry Point</i> - A or B in Higher Physical Education. You will also need to be a high level performer in one physical activity.</li> </ul>
<b>Physics</b>	<ul style="list-style-type: none"> <li>• <i>Entry Requirements</i>: Higher Physics (A/B) and Higher Mathematics (A/B/C)</li> <li>• <i>Theory</i>– three units: Rotational Motion and Astrophysics, Quanta and Waves, and Electromagnetism.</li> <li>• <i>Practical investigation</i>– This is an extended investigation where 3 experiments will be carried out, relating to an area of interest, and a full report will be produced.</li> </ul>



*Course Information  
By  
Subject Department*

# Administration & IT

The Administration and IT course is set out to develop the learners Administration and IT skills and, ultimately, enable them to contribute to the effective functioning of organisations. Administration is a growing sector which cuts across the entire economy and offers wide-ranging employment opportunities. Moreover, administrative and IT skills have extensive application not only in employment but also in other walks of life.



	National 5	Higher
<b>Content</b>	<p><b>The course has two areas of study:</b></p> <p><b>Administrative Theory in the Workplace</b></p> <p>Learners are introduced to the responsibilities of organisations, the skills/qualities and tasks (duties) of the administrative support function, and the impact of these in the workplace.</p> <p><b>IT Applications</b></p> <p>This area contains a significant practical component. Learners develop skills in IT, problem-solving, organising, and managing information. They select IT applications to create and edit business documents, gather and share information and, develop skills to communicate information. They will develop skills in using:-</p> <ul style="list-style-type: none"> <li>• Spreadsheets</li> <li>• Databases</li> <li>• Word-processing</li> <li>• Desktop publishing</li> <li>• Presentations</li> <li>• Electronic communication</li> </ul>	<p><b>The course has two areas of study:</b></p> <p><b>Administrative Theory in the Workplace</b></p> <p>Learners are introduced to the responsibilities of organisations, the skills/qualities and tasks (duties) of the administrative support function, and the impact of these in the workplace.</p> <p><b>IT Applications</b></p> <p>This area contains a significant practical component. Learners develop skills in IT, problem-solving, organising, and managing information. They select IT applications to create and edit business documents, gather and share information and, develop skills to communicate information. They will develop skills in using:-</p> <ul style="list-style-type: none"> <li>• Spreadsheets</li> <li>• Databases</li> <li>• Word-processing</li> <li>• Desktop publishing</li> <li>• Presentations</li> <li>• Electronic communication</li> </ul>
<b>Assessment</b>	<p>External assessment      42%</p> <p>Course assessment        58%</p>	<p>External assessment      42%</p> <p>Course assessment        58%</p>
<b>Minimum Entry Requirements</b>	National 4	National 5
<b>Homework</b>	Theory homework per unit.	Theory homework per unit.

# Art and Design



**Higher/ National 5 Art and Design** gives you the opportunity to:

- Challenge yourself creatively in Expressive and Design Artwork
- Express yourself personalising your work practically through the choice of subject matter and the Design Brief
- Demonstrate your drawing skills with a high quality finish in Expressive work
- Develop your art skills base
- Develop new skills within complex problem solving and evaluation
- Study the work of selected Artists and Designers

	<b>Higher/ National 5 Art and Design</b>
<b>Entry Point</b>	<b>National 5 for Higher or National 4 for National 5</b>
<b>Course Detail</b>	<p><b>Expressive Activity Unit</b></p> <ul style="list-style-type: none"> <li>• Select and investigate a suitable subject matter using a variety of art materials, techniques and /or technology creatively</li> <li>• Produce observational drawings and studies showing an understanding of the subject and the visual elements</li> <li>• Develop a range of compositions / ideas for Expressive art</li> <li>• Complete an Expressive final outcome</li> <li>• Describe and study the work of artists /their role in society, expressing facts and opinions</li> </ul> <p><b>Design Activity Unit</b></p> <ul style="list-style-type: none"> <li>• Follow a Design Brief identifying the main design opportunities, issues and constraints</li> <li>• Produce relevant investigative studies and market research in response to the developed brief</li> <li>• Use a selection of design materials, techniques and /or technology in creative ways</li> <li>• Select and develop suitable solutions.</li> <li>• Describe and study the work of Designers their methods and their impact in society</li> </ul> <p>Annotate and evaluate your Design and Expressive units</p> <p><b>The Assessment Portfolio</b></p> <ul style="list-style-type: none"> <li>• Development of the initial Expressive research sketches</li> <li>• A final piece of Expressive artwork</li> <li>• The Design brief</li> <li>• Development of the initial Design ideas</li> <li>• A final piece of Design work</li> <li>• For both Expressive and Design an evaluation of the final artwork</li> <li>• With both units it is advised to follow one clear line of enquiry</li> </ul>
<b>Course Assessment</b>	<p><b>The Assessment Portfolio</b></p> <p>The Assessment Portfolio is internally compiled and externally marked by the SQA. The portfolio contributes approx. 76% to the final award for Higher and 80% for National 5.</p> <p><b>Exam</b></p> <p>The Question Paper is externally set by the SQA and tests knowledge of Art and Design studies related to your practical Expressive and Design work. This contributes approx. 24% to the final award for Higher and 20% for National 5.</p>

# Biology

## Why Study Biology?

No one can predict the future, but this much is known: the 21st century is the time of the biologist, who will be in the forefront of the most challenging, intellectual problems, such as understanding the most elemental building blocks of the mechanisms of life, the mechanisms of memory and of learning, the molecular basis of embryonic development, and the rules that help predict the behaviour of the environment. Biology also lies at the heart of major social problems that face the human race in the coming decade, such as sensible management of the environment and the future of genetic engineering. Some of the greatest engineering feats of the future are likely to involve bioengineering projects.

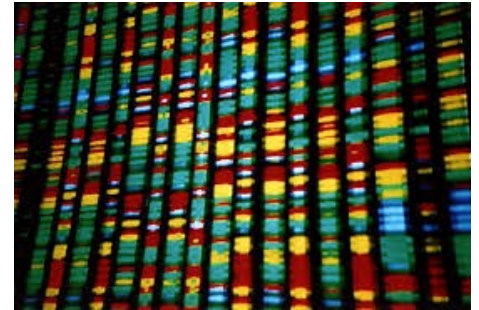

A background in biology gives you many skills and increases your career options allowing you to adapt to the changing world around you. The study of biology has an immediate relevance to all our daily lives.

## What Courses Are On Offer?

	<b>National 5</b>	<b>Higher Biology</b>
<b>Entry Point</b>	National 4 Biology	National 5 Biology (Grade A or B)
<b>Course Details</b>	<b>Cell Biology</b> <ul style="list-style-type: none"> <li>• Structure</li> <li>• Cell Transport</li> <li>• Cell Production</li> <li>• DNA</li> <li>• Energy in Cells</li> </ul>	<b>DNA and the Genome</b> <ul style="list-style-type: none"> <li>• The structure and Replication of DNA</li> <li>• Cellular Differentiation</li> <li>• The structure of the Genome</li> <li>• Mutation</li> <li>• Evolution</li> </ul>
	<b>Multicellular Organisms</b> <ul style="list-style-type: none"> <li>• Cells, Tissues and Organs</li> <li>• Biological Processes</li> <li>• Inheritance</li> <li>• Health and Disease</li> </ul>	<b>Metabolism and Survival</b> <ul style="list-style-type: none"> <li>• Metabolic Pathways</li> <li>• Cell Respiration</li> <li>• Metabolic Rate</li> <li>• Control of Metabolism</li> </ul>
	<b>Life on Earth</b> <ul style="list-style-type: none"> <li>• Biodiversity</li> <li>• Environmental Sampling</li> <li>• Adaptation</li> <li>• Behaviour</li> <li>• Food Security</li> </ul>	<b>Sustainability and Interdependence</b> <ul style="list-style-type: none"> <li>• Food Supply, Plant Growth and Sustainability</li> <li>• Plant and Animal Breeding</li> <li>• Animal Welfare</li> <li>• Symbiosis</li> <li>• Biodiversity</li> </ul>

# Business Management

Business Management introduces students to the dynamic, changing, competitive and economic environment of industry and commerce. It helps to develop skills in communicating and presenting business-related information, in a wide variety of formats to the various stakeholders of an organisation. These skills not only give students an understanding of their future place in the world of work, but as real life business contexts are widely used, they gain a greater understanding the economic and financial environment in which businesses operate.



	National 5	Higher
<b>Content</b>	<p><b>The course has five areas of study:</b></p> <p><b>Learners will develop skills, knowledge and understanding in the following areas:</b></p> <p><b>Understanding Business</b> Enterprise and the role of different types of business organisations in society. Internal and external environments in which organisations operate, and the role of stake holders in business.</p> <p><b>Management of Marketing</b> The importance to organisations of having effective marketing systems. The processes and procedures organisations use to maintain competitiveness.</p> <p><b>Management of Operations</b> The importance to organisations of having effective operations systems. The processes and procedures used to maintain quality through the effective management of suppliers, inventory, and methods of production in an ethical manner.</p> <p><b>Management of People</b> The issues facing organisations when managing people. The theories, concepts and processes relating to human resource management, and how employees contribute to the success of organisations.</p> <p><b>Management of Finance</b> The issues facing organisations when managing finance. The basic theories, concepts and processes relating to financial aspects of business, when interpreting information to solve financial problems.</p>	<p><b>The course has five areas of study:</b></p> <p><b>Learners will develop skills, knowledge and understanding in the following areas:</b></p> <p><b>Understanding Business</b> Enterprise and the role of different types of business organisations in society. Internal and external environments in which organisations operate, and the role of stake holders in business.</p> <p><b>Management of Marketing</b> The importance to organisations of having effective marketing systems. The processes and procedures organisations use to maintain competitiveness.</p> <p><b>Management of Operations</b> The importance to organisations of having effective operations systems. The processes and procedures used to maintain quality through the effective management of suppliers, inventory, and methods of production in an ethical manner.</p> <p><b>Management of People</b> The issues facing organisations when managing people. The theories, concepts and processes relating to human resource management, and how employees contribute to the success of organisations.</p> <p><b>Management of Finance</b> The issues facing organisations when managing finance. The basic theories, concepts and processes relating to financial aspects of business, when interpreting information to solve financial problems.</p>
<b>Assessment</b>	75% External assessment 25% Course assignment	75% External assessment 25% Course assignment
<b>Minimum Entry Requirements</b>	National 4	National 5
<b>Homework</b>	Theory homework every week.	Theory homework every week.

# Chemistry

## Why Study Chemistry?

Obtaining a chemistry qualification provides you with many skills such as problem solving, communication, creativity and teamwork, and so chemical scientists are much sought after and can pursue careers in many exciting and varied fields of work, such as:



- Forensic chemist, physiotherapist, doctor, cosmetic scientist, food scientist, lawyer, dentist, nuclear scientist, vet, nurse, journalist, molecular biologist, accountant, environmental chemist, chemical engineer, science teacher!

It is often very helpful to take Chemistry with Biology or Physics if you wish to complete a science degree at university

## What Courses Are On Offer?

	<b>National 5 Chemistry</b>	<b>Higher Chemistry</b>
<b>Entry Point</b>	National 4 Chemistry	National 5 Chemistry (Grade A or B) National 5 Mathematics is also beneficial
<b>Course details</b>	<p><b>Chemical Changes</b></p> <ul style="list-style-type: none"> <li>• What are substances?</li> <li>• Speeds of reaction</li> <li>• What are atoms?</li> <li>• How do atoms join together?</li> <li>• How to write chemical formulas</li> <li>• Chemical quantities</li> <li>• Acids and Bases</li> </ul>	<p><b>Chemical Changes and Structures</b></p> <ul style="list-style-type: none"> <li>• Controlling reaction rates</li> <li>• Patterns in the Periodic Table</li> <li>• Bonding and properties in ionic and covalent compounds</li> </ul>
	<p><b>Nature's Chemistry</b></p> <ul style="list-style-type: none"> <li>• Carbon Chemistry</li> <li>• Everyday household products</li> <li>• The formulas of fuels</li> <li>• Reactions of carbon</li> </ul>	<p><b>Nature's Chemistry</b></p> <ul style="list-style-type: none"> <li>• Ester's, fats and oils</li> <li>• Proteins</li> <li>• Chemistry of cooking</li> <li>• Reactions in food</li> <li>• Soaps and detergents</li> <li>• Fragrances</li> <li>• Skin care</li> </ul>
	<p><b>Chemistry in Society</b></p> <ul style="list-style-type: none"> <li>• Metals and plastics</li> <li>• Nuclear Chemistry</li> <li>• Analysis Techniques</li> </ul>	<p><b>Chemistry in Society</b></p> <ul style="list-style-type: none"> <li>• Getting the most from reactions</li> <li>• Equilibria</li> <li>• Energy changes</li> <li>• Chemical analysis</li> </ul>



# Computing Science—National 5 & Higher

Computing Science is vital to everyday life; it shapes the modern digital world in which we live and its future. These courses highlight how computing professionals are problem-solvers and designers, and the far-reaching impact of information technology on our environment and society. They help learners to understand computational processes and thinking.

They are designed for learners who are considering further study or a career in computing science including Robotics, Software Engineering, Medical Imaging, Web Design, Entertainment Technologies, Networking, Business Information Systems, Computer Gaming and Digital Forensics. They also develop skills for all learners which can be transferred to any employment area.



National 5	Higher
<b>The course has four areas of study:</b>	<b>The course has four areas of study:</b>
<b>Software design and development</b> Learners will develop skills through a range of practical tasks using appropriate software development environments. This develops their programming and computational-thinking skills by implementing practical solutions.	<b>Software design and development</b> Learners will develop skills through a range of practical tasks using appropriate software development environments. This develops their programming and computational-thinking skills by implementing practical solutions.
<b>Computer systems</b> Learners will develop an understanding of how data and instructions are stored in binary form and basic computer architecture. They gain an awareness of the environmental impact of computing systems and security precautions that can be taken to protect computer systems.	<b>Computer systems</b> Learners will develop an understanding of how data and instructions are stored in binary form and basic computer architecture. They gain an awareness of the environmental impact of computing systems and security precautions that can be taken to protect computer systems.
<b>Database design and development</b> Learners will develop skills in database design and development, through a range of practical tasks. This allows learners to apply computational-thinking skills using a range of development tools such as SQL.	<b>Database design and development</b> Learners will develop skills in database design and development, through a range of practical tasks. This allows learners to apply computational-thinking skills using a range of development tools such as SQL.
<b>Web design and development</b> Learners will develop skills in web design and development, through a range of practical tasks. This allows learners to analyse, design, implement, test and evaluate practical solutions to web-based problems, using a range of development tools such as HTML, CSS and Javascript.	<b>Web design and development</b> Learners will develop skills in web design and development, through a range of practical tasks. This allows learners to analyse, design, implement, test and evaluate practical solutions to web-based problems, using a range of development tools such as HTML, CSS and Javascript.
<b>Assessment</b> External assessment    69% Course assessment       31%	<b>Assessment</b> External assessment    69% Course assessment       31%
<b>Entry Requirements</b> National 4 Computing Science	<b>Entry Requirements</b> National 5 Computing Science
<b>Homework</b> Once a week	<b>Homework</b> Once a week

# Creative Industries: National Certificate

NC Creative Industries is a two year pathway where you can achieve an National Certificate in Creative Industries and an NPA (6) in your chosen specialism: Musical Theatre or Technical Theatre. Throughout the course you will develop skills for work and life in addition to exploring and developing specialist skills in you chosen area. Throughout the course you will contribute and organise wider school events; The Christmas Celebration, awards ceremonies, Musical Theatre Production and the schools radio station.

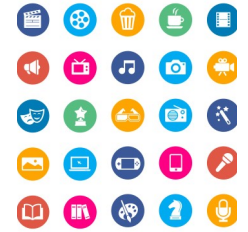

	<b>NC Creative Industries</b>
<b>Entry Point</b>	Nat 5 Drama/Music - or other relevant interest and experience.
<b>Course Details</b>	<p><b>Creative Industries</b> There are three mandatory Creative Industries units which you will complete over the two year course. In these units you will explore different creative industry job roles and develop your skills and abilities in fulfilling creative briefs through project work over the two year course.</p>
	<p><b>Specialism 1: Musical Theatre</b> Throughout the course you will gain experience and develop skills in the three elements of Musical Theatre; Acting, Singing and Dancing. You will analyse Musical Theatre performances and take part in frequent performances yourself. You will build an understanding of how the Musical Theatre Industry works and the possible job roles within it. This is a mainly practical subject with a supporting folio and end of unit assessments.</p>
	<p><b>Specialism 2: Technical Theatre</b> You will develop your skills and abilities in Technical Theatre (Lighting and Sound). You will analyse Technical theatre in performance and gain an understanding of how the industry works and the different job roles within it. You will also develop your skills and abilities in terms of your Production skills by supplying support to school events and performances by Prop and Set building, providing theatrical Make-up and a costume and wardrobe service. This is a mainly practical course with a supporting folio and end of unit assessments.</p>
<b>Assessment</b>	Assessment will take place at appropriate times throughout the course. Assessment is undertaken in a variety of ways - folio and development tasks, practical application and assignment write ups. Assessment is ongoing, with no end of year examination.

# Drama

## About the courses

The Drama Department will be offering Higher and Advanced Higher courses.

These courses afford learners the opportunity to develop knowledge and understanding of Drama from the perspective of an Actor, Designer and Director. Within the course learners will devise original Drama in response to stimulus and develop play texts for performance.



	<i>Higher</i>	<i>Advanced Higher</i>
<i>Entry Point</i>	<b><i>Drama at National 5</i></b>	<b><i>Higher Drama (A/B)</i></b>
<i>Course Details</i>	<p><b>Contemporary Performance</b></p> <p>Learners will develop skills, knowledge and understanding of roles within theatre. Following workshop sessions exploring genre, style and cultural influences on Drama learners will devise an original Drama from a stimulus for a specific audience and purpose. Additionally, learners will evaluate and analyse their own performance and that of their peers and professional theatre productions.</p> <p><b>Theatre Production</b></p> <p>Learners will develop the ability to analyse theatre texts and interpret these for performance. By exploring Drama from the perspectives of an Actor, Designer and Director learners will build and apply production skills in performance. Throughout this work, learners will develop their understanding of theatrical contexts, purpose and theatre styles, preparing them well for course assessment.</p>	
<i>Assessment</i>	<p>Performance Assessment (60%)</p> <p>Acting: Learners present two contrasting roles.</p> <p>Design: Learners design Set and another chosen production area.</p> <p>Directing: Learners will conduct a half hour rehearsal.</p> <p>Written Paper (40%)</p> <p>In the Higher written paper learners are required to write two essays and answer closed response questions.</p>	<p>Performance Assessment (60%)</p> <p>Acting: Learners present an interactive performance and a monologue.</p> <p>Design: Learners design Set and Two other chosen production areas.</p> <p>Directing: Learners will conduct a half hour rehearsal.</p> <p>Dissertation and Assignment (40%)</p> <p>Throughout the course AH student will undertake a project exploring a chosen aspect of theatre. They will also complete an assignment set by SQA</p>

# Drama—NPA in Acting Performance

This course is suitable for Learners with a strong interest in Acting and Performance, and is a SQA level 6 qualification. It is a predominantly practical course (with a supporting folio of evidence) and involves detailed exploration of Acting techniques and performance styles. The course will be of particular interest to students wishing to pursue a related course at further/higher education level. The course is likely to run alongside Higher/AH Drama and there will be lots of collaboration across levels.



	<b>NPA Acting and Performance</b>
<b>Entry Point</b>	Nat 5 Drama
<b>Course Details</b>	<p><b>Professional Theatre in Context</b></p> <p>In this unit learners will develop an understanding of the different roles and responsibilities of the theatre production team in addition to exploring contemporary theatre practice and comparing and contrasting Theatrical performances. By devising an original Drama from a stimulus learners will demonstrate their understanding of genre, style, purpose and diverse acting techniques.</p>
	<p><b>Theatre Skills in Performance</b></p> <p>In this unit learners will experiment with different acting styles, techniques and methods before developing a text for performance. The text will be chosen collaboratively with a view to performing the production to a specific invited audience. Learners may also be involved in crossover performances with Nat 5/ Higher candidates.</p>
<b>Assessment</b>	Learners practical work will be assessed on an ongoing basis by means of teacher observation and an assessment checklist. In addition, learners will keep a logbook/diary detailing their progress throughout the rehearsal process and complete unit assessment tasks which evaluate their own and others performance.

# Early Learning and Childcare

## Why Early Learning and Childcare?

This course is an excellent opportunity for pupils interested in working within early education, primary education or childcare sectors. The course helps to develop employability skills and many transferable skills which are valuable in the workplace.

The National 5 course is a progression from the National 4 course and begins to prepare students for working in the sector.

At National 5, learners will develop core skills, an understanding of the work place, positive attitudes to learning as well as employability skills.



## What does the course involve?

National 5 Skills for Work: Early Learning and Childcare is an introductory qualification that will help learners to understand some of the demands and responsibilities of working in the early learning and childcare sector.

This qualification covers areas such as:

- Development and Wellbeing of Children & Young People
- Play in Early Learning and Childcare
- Working in Early Learning and Childcare.

Pupils will also develop transferable employability skills, including:

- An understanding of the workplace and the employee's responsibilities (eg time-keeping, appearance, customer care)
- Self-evaluation skills
- Positive attitude to learning
- Flexible approaches to solving problems
- Adaptability and positive attitude to change
- Confidence to set goals, reflect and learn from experience
- Skills to become effective job-seekers and employees



At SCQF level 5, learners work alone or with others on straightforward tasks with support.

## Assessment

The Skills for Work Course in Early Learning and Childcare consists of 3 mandatory Units and 5 optional Units. These will be assessed continuously throughout the year and there will be no formal exam at the end of the year. Pupils will need to pass all of the required units to gain the full course award.

## Possible Careers

Following courses in Early Education and Childcare can lead to a variety of careers such as early years work, social care, social worker, youth work, health care, day centre work, nursery teacher, nurse, etc..

# English

## Why Study English?

English helps you to:

- Develop your skills in reading, writing listening and talk.
- Develop individual thought, analysis and evaluation.

You will be expected:

- To take increasing responsibility for your own time.
- To organise your materials, your time and yourself to ensure you achieve.



	<b>National 5 English</b>	<b>Higher English</b>
<b>Entry Point</b>	<b>National 4</b> (in consultation with English Teacher)	<b>National 5</b> (National 5 pass and consultation with English Teacher)
<b>Course Details</b>	<p>The Course offers learners opportunities to develop and extend a wide range of skills. In particular, the Course aims to enable learners to:</p> <ul style="list-style-type: none"> <li>• listen, talk, read and write</li> <li>• understand, analyse and evaluate texts, including Scottish texts</li> <li>• create and produce texts</li> <li>• apply knowledge and understanding of language</li> </ul>	<p>The Course offers learners opportunities to develop and extend a wide range of skills. In particular, the Course aims to enable learners to:</p> <ul style="list-style-type: none"> <li>• listen, talk, read and write</li> <li>• understand, analyse and evaluate texts, including Scottish texts</li> <li>• create and produce texts</li> <li>• apply knowledge and understanding of language</li> </ul>
<b>Course Assessment</b>	<p>Internal assessment of talk and listening</p> <p>Writing folio: 1 creative/1 discursive – 30%</p>	<p>Internal assessment of talk and listening</p> <p>Writing folio: 1 creative/1 discursive – 30%</p>
<b>Exam Details</b>	<p>Paper 1 – Reading for UAE – 30%</p> <p>Paper 2 – Critical Reading – 40%</p>	<p>Paper 1 – Reading for UAE – 30%</p> <p>Paper 2 – Critical Reading – 40%</p>

# ESOL

## Why Study ESOL?

This qualification is for pupils whose first language is not English and it assesses Reading, Writing, Listening and Talking. The topics covered are relevant to everyday work, study and social situations.

The course is ideal for students who find English difficult due to the fact that they are bilingual. Often, bilingual pupils perform better in ESOL than they do in the English. It will be taught by members of the English department so there will be no need to travel to other schools.

The ESOL qualification is widely accepted by universities and is seen as being the equivalent of the English qualification for most courses.

Finally, if S5 pupils achieve Nat 5 this year, then it is likely that they will be offered the chance to sit the Higher exam in S6.

## What Course Is On Offer?

	<b>National 5—ESOL</b>
<b>Entry Point</b>	National 4 English—consultation with SfL/EAL
<b>Course Details</b>	<p>The Course offers opportunities to develop and extend a wide range of skills. In particular, the Course aims to enable learners to develop the ability to:</p> <ul style="list-style-type: none"><li>• read, write, listen, and speak, in English</li><li>• understand and use English language</li><li>• apply knowledge and understanding of English language</li></ul> <p>These skills will be taught by exploring the following topics:</p> <ul style="list-style-type: none"><li>• everyday life</li><li>• work</li><li>• Study</li></ul>
<b>Course Assessment</b>	Internal assessments in: listening, speaking, reading and writing
<b>Exam Details</b>	<p>Component 1: listening; reading and writing - 70%</p> <p>Component 2: speaking and listening - 30%</p>



# Enterprise & Employability

## National Progression Award – SCQF Level 4 or 5

This course aims to provide students with enterprise and employability skills, together with fundamental core skills required for work. It aims to raise awareness of self-employment and to promote customer service skills. In addition to this, it will provide students with a hands-on approach to learning about how businesses operate.



The course has been developed to prepare students for the demands of the work environment and therefore enhance their opportunities for employment.

<p><b>Content</b></p>	<p>Units students must complete include:</p> <ul style="list-style-type: none"> <li>• Personal Development: Self and Work</li> <li>• Enterprise Activity</li> </ul> <p>Students will then choose 2 credits from the following:</p> <ul style="list-style-type: none"> <li>• Skill for customer care</li> <li>• Customer service skills</li> <li>• E-Commerce</li> <li>• Marketing</li> <li>• Finance</li> <li>• Working with others</li> </ul>
<p><b>Assessment</b></p>	<p>You are expected to successfully create and run your own enterprise activity.</p> <p>In addition to this, you must complete SQA internal assessments.</p> <p>All units are internally assessed by your class teacher, therefore there is no external exam.</p>
<p><b>Minimum Entry Requirements</b></p>	<ul style="list-style-type: none"> <li>• Being enthusiastic</li> <li>• Having imagination and determination</li> <li>• Being able to work as part of a team</li> <li>• Being an effective contributor</li> <li>• Being a confident individual</li> <li>• Willing to work out of school</li> </ul>
<p><b>Homework</b></p>	<p>This will involve working the extra hours to get your business up and running.</p> <p>Tasks related to other assessed units.</p>



# Geography

## Why Study Geography?

Geography adds to your understanding of the modern world, especially the ways in which people and the environment interact locally, nationally and globally.

- It is vital in developing your understanding of the world in a balanced, critical and sensitive way.
- It provides an essential bridge between the social sciences and pure science at university.
- It equips you with skills which apply to a wide range of careers



Geographical methods and techniques are built into both courses. This puts theory into practice and includes the opportunity to carry out fieldwork.

	<b>National 5</b>	<b>Higher</b>
<b>Entry Point</b>	<i>National 4 in Geography or another Social Subject</i>	<i>National 5 in Geography or another Social Subject</i>
<b>Course Details</b>	<p><b>Physical Environments</b></p> <ul style="list-style-type: none"> <li>• Weather and climate</li> <li>• Glaciated uplands/Rivers</li> <li>• Coasts/Limestone</li> <li>• Land use, conflict &amp; management</li> <li>• Mapping skills</li> </ul>	<p><b>Physical Environments</b></p> <ul style="list-style-type: none"> <li>• Atmosphere (air)</li> <li>• Hydrosphere (water)</li> <li>• Lithosphere (rock)</li> <li>• Biosphere (soil)</li> </ul>
	<p><b>Human Environments</b></p> <ul style="list-style-type: none"> <li>• Urban &amp; Rural Landscapes</li> <li>• Population Issues</li> <li>• Development</li> </ul>	<p><b>Human Environments</b></p> <ul style="list-style-type: none"> <li>• Population and Migration</li> <li>• Rural management</li> <li>• Urban management</li> </ul>
	<p><b>Global Issues</b></p> <ul style="list-style-type: none"> <li>• Climate Change</li> <li>• Health</li> </ul>	<p><b>Global Issues</b></p> <ul style="list-style-type: none"> <li>• Development and Health</li> <li>• Climate change</li> </ul>
	<p><b>Development of Geographical Skills</b></p>	<p><b>Application of Geographical Skills</b></p> <ul style="list-style-type: none"> <li>• Map work</li> <li>• Data Handling</li> <li>• Decision-making</li> </ul>
<b>Assessment</b>	<ul style="list-style-type: none"> <li>• Fieldwork</li> <li>• Assignment (20 marks)</li> <li>• Final exam (80 marks)</li> </ul>	<ul style="list-style-type: none"> <li>• Fieldwork</li> <li>• Assignment (30 marks)</li> <li>• Final exam Paper 1—100marks Paper 2— 60 marks</li> </ul>

# Graphic Communication

## Why Choose Graphic Communication?

**Higher / National 5 Graphic Communication** gives you the opportunity to:

- develop more complex manual technical drawing skills
- develop more complex computer graphics skills
- produce a graphic presentation of a commercial product
- develop a knowledge of the use of graphic communication in industry.



## How is the course organised?

You will work through a series of drawing topics. At the end of each topic you will do a mini project demonstrating the use of the type of graphic in commerce or industry.

## How are you assessed?

By the end of S4 you will have completed two Units and projects:

### Unit 1: 2D Graphics

orthographic views  
geometric drawing  
engineering drawing  
colour illustration techniques  
DTP

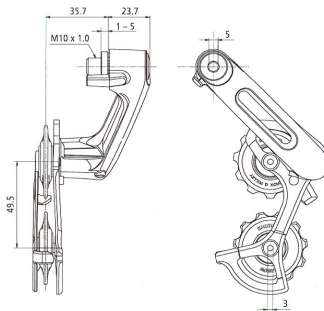

### Unit 2: 3D Graphics

Oblique, isometric & planometric views  
Perspective sketching  
3D computer modelling  
3D promotional graphics

### Course Assessment Project work

2D and 3D computer aided drawing (CAD)  
Desk top publishing (DTP)  
Knowledge of use of CAD in industry

## How is the Course assessed?

Assessment is by a Course Assessment Project which is externally marked and theory exam.

## Career Opportunities

As well as being a desirable qualification for some college and university courses, Graphic Communication is essential for many careers and very useful for a great many more. Typical careers include:

- industrial draughting
- engineering
- graphic design
- architecture and building services
- product design
- interior design



# History

## Why Study History?

History provides you with the knowledge and understanding of:

- ◆ world issues today
- ◆ how your world has developed
- ◆ your heritage
- ◆ and helps you develop essential skills



	<b>National 5</b>	<b>Higher</b>
<b>Entry Point</b>	National 4 in History or another Social Subject	National 5 in History or another Social Subject
<b>Course Details</b>  <b>You will learn:</b>	<p><b>Historical Study: Scottish The era of the Great War 1900-1928</b></p> <ul style="list-style-type: none"> <li>• Scots on the Western Front</li> <li>• Domestic Impact of War: Society &amp; Culture</li> <li>• Domestic Impact of War: Industry and Economy</li> <li>• Domestic Impact of War: Politics</li> </ul>	<p><b>Scotland and the Impact of the Great War 1914-1928</b></p> <ul style="list-style-type: none"> <li>• Overview of Scottish politics and the economy in 1914</li> <li>• Scots on the Western Front</li> <li>• Domestic Impact of War: Society &amp; Culture</li> <li>• Domestic Impact of War: Industry and Economy</li> <li>• Domestic Impact after the Great War</li> <li>• Significance of the Great War in the development of a Scottish nation.</li> </ul>
	<p><b>Historical Study: European &amp; World—Hitler &amp; Nazi Germany 1919-1939</b></p> <ul style="list-style-type: none"> <li>• The impact of World War I on Germany</li> <li>• Opposition to the Treaty of Versailles</li> <li>• Formation and characteristics of the Weimar Republic</li> <li>• Attempts to overthrow the Weimar Republic</li> <li>• Reasons for the rise of Hitler</li> <li>• Nazi consolidation of power</li> <li>• Nazi's in power—treatment of Jews, Nazi economic policies, militarism, youth movements, education and Nuremburg rallies</li> </ul>	
	<p><b>Historical Study: The Making of Modern Britain 1880-1951</b></p> <ul style="list-style-type: none"> <li>• Background to poverty in the 19th century</li> <li>• Reasons why the Liberal Government 1906-1914 introduced welfare reform</li> <li>• Impact of World War II</li> <li>• Labour reforms 1945-51 and the establishment of the Welfare State</li> </ul>	<p><b>Britain 1851-1951</b></p> <ul style="list-style-type: none"> <li>• Reasons why women gained the vote</li> <li>• Reasons why the Liberal Government 1906-1914 introduced welfare reform</li> <li>• Impact of Liberal reforms 1906-1914</li> <li>• Labour reforms 1945-51 and the establishment of the Welfare State</li> </ul>
<b>Assessment</b>	Pupils will sit a written exam at the end of the course worth 80 marks and will complete an Added Value Assignment worth 20 marks.	<p>Pupils will sit a written exam at the end of the course</p> <ul style="list-style-type: none"> <li>◆ British, European &amp; World History paper—44 marks</li> <li>◆ Scottish History paper—36 marks</li> <li>◆ Higher Assignment—30 marks</li> </ul>

# Hospitality : Practical Cookery—National 5

<p><b>About the Course</b> This course is for you if you: -</p> <ul style="list-style-type: none"> <li>• have an interest in cookery</li> <li>• have an interest in providing unique and creative food products</li> <li>• are inspired by media presentations such as Masterchef</li> <li>• are interested in a career in the Hospitality Industry</li> <li>• are interested in preparing meals independently for yourself and others</li> </ul>	<p><b>Possible Careers</b> This course can lead to further study and/or employment in the following areas:</p> <ul style="list-style-type: none"> <li>• The Hospitality Industry.</li> <li>• The Tourism Industry.</li> <li>• Food Technology.</li> <li>• Child care.</li> <li>• Product Design</li> <li>• Enterprise</li> <li>• Environmental Health</li> </ul> 
---	--

## Course Aims

This course aims to develop life skills and personal effectiveness in terms of cookery. It will enable learners to develop cookery related knowledge understanding and skills for use in the home, in the wider community and ultimately in employment. Learners will participate in engaging, motivating and relevant learning experiences in real-life hospitality contexts.

Learners will:

- Proficiently use a range of cookery skills, food preparation techniques and cookery processes when following recipes
- Select and use ingredients to produce and garnish or decorate dishes
- Develop an understanding of the characteristics of ingredients and an awareness of their sustainability
- Develop an understanding of current dietary advice relating to the use of ingredients
- Work safely and hygienically

The course contains a significant practical component and is supported by related theory. It uses real-life hospitality contexts which makes it relevant to the world of work.

## Assessment

In order to achieve the course award, learners must undertake the following assessments

Question Paper	Assignment	Practical Activity
<p>The question paper requires candidates to draw on and apply knowledge and understanding of a sample from all areas of the course. <b>30 mks</b></p>	<p>The assignment and practical activity are inter-related and will be assessed using one activity. The assignment involves the <b>planning</b> of a 3-course meal . <b>18mks</b></p>	<p>The practical activity involves the <b>preparation and presentation</b> of the 3-course meal. The practical activity requires candidates to clearly demonstrate application and knowledge at an appropriate level, related to the course content. <b>82mks</b></p>

## Homework

Learners will be expected to carry out further reading and research to consolidate their knowledge and further their understanding. Learners will benefit by practicing practical processes and techniques at home.

## Progression

This course or its units may provide progression to:

- Other qualifications in Hospitality or related areas available at colleges /universities
- National 5 Hospitality; Practical Cake Craft
- Employment or training

**Entry Requirements**—Pupils who have studied Hospitality at National 4 in S4.  
Pupils who have an interest in the subject area.

# Human Biology

## Why Choose Human Biology?

Biology, the study of living organisms, plays a crucial role in our everyday life, and is an increasingly important subject in the modern world. Biology affects everyone, and biologists work to find solutions to many of the world's problems. Advances in technology have made human biology more exciting and relevant than ever.

The Human Biology course allows candidates to acquire a deeper understanding of cellular processes, physiological mechanisms and their impact on health, aspects of the nervous system, and defence mechanisms as they apply to the human species.

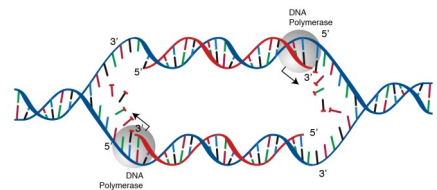
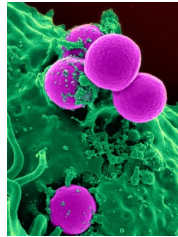
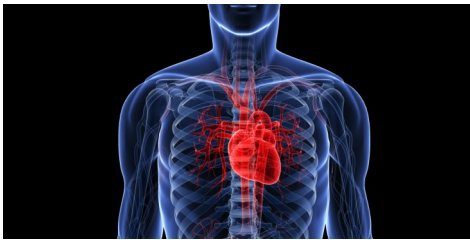

## Where Could A Human Biology Qualification Lead?

Human Biology is a relevant qualification in the following areas of work:

nursing, midwifery, sports science, physiotherapy, sports coaching, sports therapy, biotechnology and forensic science.

## How is the course organised?

The course will be organised into 3 broad, general units.

- Human Cells
- Physiology and Health
- Neurobiology and Immunology

## What kind of things will you be doing?

Some of the Biology topics covered are Human Cells, Physiology, Health, Neurobiology, Immunology, Pathology, Energy Systems and Muscle Cells, Body Defences against Pathogens, Clinical Trials of Vaccines and Drugs, Division and Differentiation of Human Cells, and Antenatal and Post Natal Screening.

These are taught through a variety of experiences such as lab work, microscope work and research. You will learn collaboratively, working with others to develop your understanding.

## How will you be assessed?

Assessment for Human Biology involves:

- end of unit assessments (involving knowledge and skills questions)
- practical investigation
- end of year examination

## Homework Requirements

Homework will be set weekly to help you develop your understanding. Homework will take a variety of forms, including research, problem solving questions, communication tasks and revision for tests.

# Mathematics

## Why Study Mathematics?

### Applications of Mathematics

Applications of Mathematics is a good basis for any course which requires good Numeracy skills and relies on the Maths used in everyday life eg Business Studies and Retail. National 5 Applications of Maths may be an alternate entry qualification to National 5 Mathematics.

### Mathematics

National 5 level Mathematics may be required for college courses and is required for further study at National Certificate level.

National 5 level Mathematics is usually a requirement for degrees eg nursing, teaching and further study at Higher National Certificate level or above.

Higher Mathematics is a necessary requirement for further study in mathematics, physics, chemistry, applied sciences, all kinds of engineering and technology, medicine, veterinary studies, computing, financial services, business and marketing.

	<b>National 4/5 Applications of Mathematics</b>	<b>National 5 Mathematics</b>	<b>Higher Mathematics</b>
<b>Entry Requirement</b>	Pass at National 3/4 Applications of Mathematics	Pass at National 4 Mathematics and recommendation from teacher	Pass at National 5 Mathematics
<b>Assessment</b>	3 Unit assessments and a final internal assessment covering all coursework. Internal for Nat 4, external for Nat 5	An external exam	An external exam
<b>Course Content</b>	3 units covering: <ul style="list-style-type: none"> <li>• Managing Finance and Statistics</li> <li>• Geometry and Measures</li> <li>• Numeracy</li> </ul>	Topics include: <ul style="list-style-type: none"> <li>• Algebra</li> <li>• Trigonometry</li> <li>• Geometry</li> <li>• Quadratic functions</li> </ul>	Topics include: <ul style="list-style-type: none"> <li>• Calculus</li> <li>• Vectors</li> <li>• Functions</li> <li>• Quadratic Theory</li> <li>• Exponential and Logarithmic functions</li> </ul>

# Media Studies

## About the courses

Media will be offered at National 4/5.

The Courses enable learners to develop their understanding of the role of Media in our society. It offers opportunities to analyse Media content (film, TV, advertising etc) and combine theory and practice by creating their own Media content.



	<b>National 5</b>	
<b>Entry Point</b>	English at Nat 4/5 or Drama N4/5	
<b>Unit Details</b>	<p><b>Analysing Media Content</b></p> <p>Through analysing media content learners will build knowledge and understanding of Media literacy and explore how Media content is constructed. Learners will also explore the effects of Media content on its audience and analyse how Media is constructed to achieve a desired impact on society.</p>	
	<p><b>Creating Media Content</b></p> <p>When creating media content learners will acquire skills, knowledge and understanding to be able to create media content relevant to particular purposes, audiences and contexts. Learners will create media in the form of short film, film trailers, print/moving advert, posters or magazine covers. Learners will also evaluate the success of the Media content created.</p>	
	<p><b>National 5</b></p> <p>The Course Assessment at all levels involves the completion of an assignment in response to a given brief. At National 5 level there is also a question paper which assesses learners ability to analyse media content in context and media texts.</p>	



# Modern Languages—Spanish

## Why Study a Modern Language?

- Many employers consider knowledge of a modern foreign language an asset.
- Primary teachers are expected to teach at least one but sometimes two languages.
- The course will develop your oral and presentation skills which are essential in the modern work place.
- The course examines issues of contemporary life and gives you the opportunity to develop your opinions further on a range of topics.
- Studying a foreign language gives you knowledge about another country's culture and the chance to develop international contacts, friendships and life long interest.



## What Courses Are On Offer?

	<b>National 5 French / Spanish</b>	<b>Higher French / Spanish</b>
<b>Entry Point</b>	<b>National 4</b> (or by arrangement with Department)	<b>National 5</b> (or by arrangement with Department)
<b>Course Details</b>	<p>The course offers opportunities to develop and extend a wide range of skills. It will enable you to:</p> <ul style="list-style-type: none"> <li>• Listen and talk, read and write in a modern language</li> <li>• Understand and use a modern language</li> <li>• Apply knowledge and understanding of a modern language</li> </ul> <p>These skills will be taught by exploring the following topics:</p> <ul style="list-style-type: none"> <li>• Society</li> <li>• Learning</li> <li>• Employability</li> <li>• Culture</li> </ul>	<p>The course offers opportunities to develop and extend a wide range of skills. It will enable you to:</p> <ul style="list-style-type: none"> <li>• Listen and talk, read and write in a modern language</li> <li>• Understand and use a modern language</li> <li>• Apply knowledge and understanding of a modern language</li> </ul> <p>These skills will be taught by exploring the following topics:</p> <ul style="list-style-type: none"> <li>• Society</li> <li>• Learning</li> <li>• Employability</li> <li>• Culture</li> </ul>
<b>Course Assessment</b>	Writing Assessment submitted to SQA	Writing Assessment submitted to SQA
<b>Exam Details</b>	Paper 1: reading & writing Paper 2: listening  Talk Performance	Paper 1: reading & directed writing Paper 2: listening  Talk Performance



# Modern Studies

## Why Study Modern Studies?

- Modern Studies enables learners to have a knowledge and understanding of the contemporary political, social and economic challenges affecting people today. It helps develop a variety of skills such as identifying selectivity in a source, drawing conclusions and justifying decisions. Studying the subject encourages pupils to engage with society on the issues of importance to them and society as a whole.
- Modern Studies helps students develop critical thinking, cooperative learning, oral and written skills which are all essential for the world of work.
- Due to the critical analysis and essay writing skills involved in Modern Studies, it is an ideal Higher level subject for pupils intending to progress to University. It is particularly useful for careers in Law (Advanced Higher links directly to aspects of the first year law degree), Medicine (social aspects of health and healthcare funding are studied in detail at Higher), Journalism, the Civil Service, the Police, Teaching, Social Policy work and academic research.

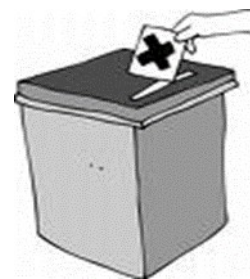

## What Courses Are On Offer?

	<b>National 5</b>	<b>Higher</b>
<b>Entry Point</b>	<i>National 4 in Modern Studies or another Social Subject</i>	<i>National 5 in Modern Studies or another Social Subject</i>
<b>Course Details</b>	<p><b>Democracy in the UK</b></p> <ul style="list-style-type: none"> <li>• Role of representatives</li> <li>• Functions of government</li> <li>• Taking part in politics</li> <li>• Elections</li> <li>• Pressure groups</li> </ul>	<p><b>Democracy in Scotland and the UK</b></p> <ul style="list-style-type: none"> <li>• Role of UK &amp; Scottish Government</li> <li>• Voting systems</li> <li>• Voting behaviour (media, class)</li> <li>• Pressure groups</li> </ul>
	<p><b>Social Issues In the UK</b></p> <ul style="list-style-type: none"> <li>• Nature of social inequality</li> <li>• The causes of social inequality</li> <li>• The consequences of social and economic inequality</li> <li>• Responses to social and economic inequality</li> </ul>	<p><b>Social Issues in the UK</b></p> <ul style="list-style-type: none"> <li>• Evidence of social inequality (health, income, employment)</li> <li>• Impact of social inequality on different groups and attempts to tackle inequalities</li> </ul>
	<p><b>International Issues</b></p> <ul style="list-style-type: none"> <li>• Social, economic and political study of the USA</li> </ul>	<p><b>International Issues</b></p> <ul style="list-style-type: none"> <li>• Social, economic and political study of the USA</li> </ul>
<b>Assessment</b>	Pupils will sit a written exam at the end of the course worth 80 marks and will complete an Added Value research assignment worth 20 marks.	Pupils will sit a written exam, with 2 papers, at the end of the course. Paper 1 is worth 52 marks and Paper 2 is worth 28 marks. Students also complete an Added Value research assignment worth 30 marks.

# Music

## About the course

At both NPA and Higher level Music offers learners the opportunity to gain a broad practical experience of performing, creating and understanding Music. The courses allow for both independent and collaborative work and help learners to plan and organise, to make decisions and to take responsibility for their own learning.



	NPA	Higher
Entry Point	Previous Music Experience	Pass at National 5
Course details	<p><b>Understanding Music</b> Learners will develop knowledge and understanding of music concepts, music literacy and analysing music through listening and practical application activities. Those following the NPA course will demonstrate their understanding through practical work.</p>	
	<p><b>Composing</b> Learners will combine theory and practice to compose their own piece of music. Learners will plan their own learning with support from the class teacher to create one complete piece of music. The musical composition will allow learners to explore and apply ideas using different elements (melody, harmony, rhythm, timbre and structure). Learners will also review their work and progress throughout the composition process.</p>	
	<p><b>Performing</b> Learners will develop their abilities in interpreting and performing on two instruments (or one instrument and voice). By combining theory and practice learners will develop performance skills in terms of; melodic accuracy, rhythmic accuracy, tempo and flow, mood and character, tone and dynamics. There is opportunity for both collaborative and individual work during the development of performance. The NPA course is fully performance based.</p>	
	Performing:	A visiting assessor will grade learners on both their instruments
	Composing:	The composition assignment and review are completed in class and sent to the SQA to be assessed
	Question paper:	This takes the form of a listening exam and is externally assessed

# Music Technology

## About the course

National 5 Music Technology focuses on the creative, often experimental, blending of music and technology. This course is very practical led allowing pupils to learn independently and collaboratively. Music Technology is a new and exciting course and although benefits from the ability to play an instrument, it is not a compulsory. You will explore the world of Sound production, Film Foley, Radio Broadcasting, Sound for gaming and Studio Recording.





	Nat 5	
<b>Entry Point</b>	<b>Previous Music Tech Experience</b>	
<b>Course details</b>	<p><b>Developing an Understanding of 20th and 21st Century Music</b></p> <p>Candidates develop listening skills, enabling them to identify a range of genres and styles and their main attributes, and relevant music concepts in the context of 20th and 21st century music. They develop an understanding of aspects of the music industry, including a basic awareness of the implications of intellectual property rights. They will also research the progression of Music players.</p>	
	<p><b>Developing music technology skills</b></p> <p>Throughout the course, candidates develop a range of skills and techniques relating to the creative use of music technology hardware and software to capture and manipulate audio. These skills include using appropriate audio input devices, applying microphone placement techniques, constructing the signal path for multiple inputs, setting input gain and monitoring levels, overdubbing and editing tracks, equalisation, time domain and other effects, and mixing techniques.</p>	
	<p><b>Music technology contexts</b></p> <p>Candidates gain experience in using music technology skills to capture and manipulate audio and sequenced data, and mix down to an audio master in appropriate file format, in a range of contexts such as live performance, radio broadcast, composing and/or sound design for film, audiobooks and computer gaming.</p>	
	<p><b>Assignment:</b> Two assignments will be completely during the year and will be marked externally. This will be 70% of overall mark</p> <p><b>Question paper:</b> This takes the form of a listening exam and is externally assessed. This will be 30% of overall mark</p>	

# People and Society: National 4

## Social Subjects Faculty

People and Society is a flexible and inter-disciplinary course offering learners the opportunity to study themes, issues and topics in the Social Subjects faculty. Learners gain a range of skills which will enhance opportunities to engage positively in society, as well as knowledge and understanding of society and their place in it. Skills covered are investigating skills, comparing and contrasting and decision making. The National 4 course consists of 4 units including an Added Value Assignment. Each unit will cover a specific topic and skill. All units are internally assessed on a pass/fail basis. **There is no final exam for this course.**

Examples of previous topics are in the table below.

<b>National 4</b>	
<b>Entry Point</b>	National 3 or National 4 in any Social Subject (Geography, History or Modern Studies).
<b>Unit 1</b>	<p><b>Comparing &amp; Contrasting:</b></p> <p>The Assassination of John F Kennedy</p> 
<b>Unit 2</b>	<p><b>Investigating:</b></p> <p>Global Terrorism</p> 
<b>Unit 3</b>	<p><b>Making Decisions:</b></p> <p>Why did women gain the vote?</p> 
<b>Unit 4</b>	Added Value Assignment—this can be on any relevant topic of the student's choice.

# Photography—Higher

## Skills Developed on this course

- Develop your knowledge and understanding of the properties of light and image formation.
- Develop your knowledge and understanding of camera controls and a range of photographic techniques and processes.
- Investigating and analysing the major historical, scientific, social, and cultural factors influencing photographers and their work.
- Producing investigative research for photography, and planning, shooting, printing and developing photographs.
- Exploring and experimenting with a range of photographic media, manipulation techniques and processes.
- Producing and presenting creative and technically proficient photographs.
- Effectively managing and storing photographic images.

	<b>Higher Photography</b>
<b>Entry Point</b>	<ul style="list-style-type: none"> <li>• National 5 Art &amp; Design and or NPA level 5 Photography</li> <li>• National 5 English</li> </ul>
<b>Course Detail</b>	<p><b>COURSE INFORMATION</b></p> <p><b>Project:</b> Image Making and Contextual Studies:</p> <ul style="list-style-type: none"> <li>• Learn how to plan and carry out practical photographic work.</li> <li>• Investigate selected photographers' work and practice and explain how external influences impact on these.</li> <li>• Use understanding of photographers practice to develop your own personal approaches to photography.</li> <li>• Learn and apply a range of image making techniques.</li> <li>• Develop creative problem-solving skills as you resolve visual and technical problems.</li> <li>• Reflect on and evaluate the effectiveness of your practice and the qualities of your photographic work.</li> </ul> <p><b>Question Paper:</b></p> <p>The question paper requires pupils to integrate and apply knowledge and skills from across the course. It allows them to demonstrate their knowledge and understanding of light and image formation, camera controls, image-making techniques and their effects.</p>
<b>Course Assessment</b>	<p>Component 1 — Question paper: 30 marks (23%)</p> <p>Component 2 — Project: 100 marks (77%)</p>

# Physical Education

## About the Course(s)

These courses are for you if you:-

- currently enjoy PE
- are physically able
- are prepared to work with others
- want a course which is mainly practical

## Possible Careers

Following courses in Physical Education can lead to variety of careers such as:

- Professional Sports person, PE teacher
- Sports Coach, Sports Physiotherapist,
- Sports Analyst, Leisure Management,
- Armed Forces, Police Service and the Fire Service

## National 5/Higher Physical Education

The course has two mandatory components:

### Physical Education: Performance Skills

In this component, learners will develop a broad and comprehensive range of complex movement and performance skills through a range of physical activities. They will select, demonstrate, apply and adapt these skills, and will use them to make informed decisions. They will also develop their knowledge and understanding of how these skills combine to produce effective outcomes.



### Physical Education: Factors Impacting on Performance

In this component, learners will develop their knowledge and understanding of the factors that impact on personal performance in physical activities. Learners will consider how mental, emotional, social, and physical factors can influence effectiveness in performance. They will develop knowledge and understanding of a range of approaches for enhancing performance and will select and apply these to factors that impact on their personal performance. They will create development plans, modify these and justify decisions relating to future personal development needs.

The courses at National 5 and Higher are similar. The award is determined by the quality of performance in the two components of the course. The activities for the course will be selected in negotiation with all students.

## Assessment

In order to achieve the **course award**, learners must undertake the following assessments::

<b>National 5 Course:</b>	2 x One-off Performances in different activities	(30 marks each)
	Portfolio of Evidence – submitted to SQA	(60 marks)
<b>Higher Course:</b>	2 x One-off performances in different activities	(30 marks each)
	Course Exam	(50 marks)

## Sports Leadership (Offered to S6 pupils)

This course aims to develop pupils' planning, organisation and leadership skills through sport. Pupils studying this course will also complete a performance unit at Higher/Advanced Higher level throughout the year.



The sports leadership course will be mainly practical and will cover units such as Lesson Planning, Communication, Managing Behaviour, Health and Safety, First Aid and Tournaments/Competitions.

As part of the course, pupils will also have to complete 10 hours of voluntary service, which could be organised themselves out of school or could involve helping with school teams or after-school clubs.

Entry Requirements	
<b>National 5 PE</b>	S3 elective PE course <b>or</b> National 4 PE
<b>Higher PE</b>	National 5 PE <b>or</b> National 5 English
<b>Sports Leadership</b>	S6 pupils who have studied PE in S4 or S5



# Physics

## Why Study Physics?

- Physics is the study of everything - From the tiniest sub atomic particles to the largest galaxies and beyond! It gives us powerful tools to help us to express our thoughts and creativity; to see the world in new ways and help change it for the better.

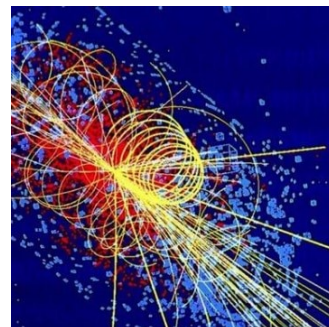

- A qualification in Physics is highly thought of by employers and universities. It provides higher core skills needed for analyzing data and solving problems in the sciences, engineering and medicine, as well as in ICT, economics, finance, management, law and public policy.
- Physics makes an excellent combination with either Chemistry or Biology, as well as with Maths, and helps strengthen knowledge and skills in these subjects respectively. It is taught through experiments and online resources with weekly homework.

## What Courses Are On Offer?

	<b>National 4/5 Physics</b>	<b>Higher Physics</b>
<b>Entry Point</b>	National 3 Physics or National 4 Biology or Chemistry	National 5 Physics National 5 Maths
<b>Course Details</b>	<b>Dynamics and Space</b>  Vectors and scalars, Movement, Forces, space exploration and cosmology	<b>Our Dynamic Universe</b>  Vectors, motion, Newton's laws, momentum, and impulses, special relativity and origins of the universe
	<b>Electricity and Energy</b>  Electrical Circuits, Electrical Components, Household Energy, Heat and Energy Transformations.	<b>Electricity</b>  Analogue Circuits, alternating current, capacitance and semiconductors
	<b>Waves and Radiation</b>  Sound, Light, Electromagnetic Spectrum, Radioactivity and Nuclear Power.	<b>Particles and Waves</b>  Fundamental particles, nuclear reactions, wave-particle duality and the behaviour of light
		<b>Researching Physics</b>  An in depth investigation into a specific aspect of the physics course developing research and investigative skills.

# Practical Electronics: National 4/5

## Why Choose Practical Electronics

### Why Choose Electronics?

Electronics impact greatly on our everyday lives. From our mobile phones to our laptops to our simple calculators, electronic circuits drive them all and they are invaluable in today's society but how do they work? How are electronic circuits constructed? This course provides an insight into the world of electronics. You will learn how simple electronic circuits work and will have the opportunity to build circuits, developing techniques such as soldering. This course will lead to a National 4 or National 5 award.

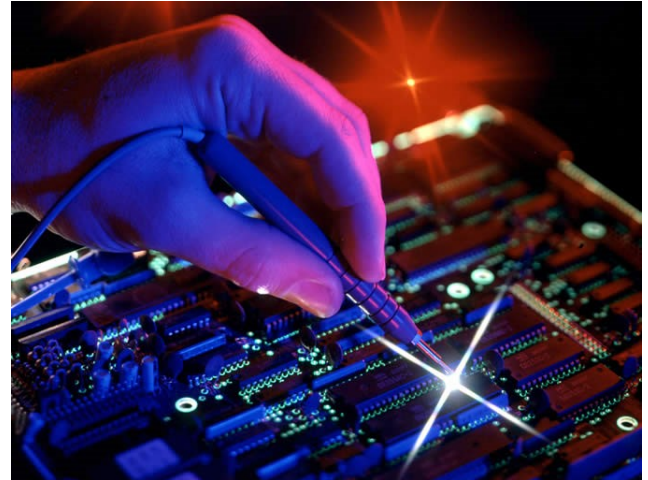

### Where Could An Electronics Qualification Lead?

Through an understanding of electronic circuits and their construction, opportunities would be opened up in the world of electronic engineering. The skills and knowledge developed could lead to jobs with companies manufacturing or repairing electronic devices, many of which are located throughout central Scotland.

### How Is The Course Organised?

The course is divided into three units.

**Circuit Design:** You will learn how circuits are constructed and how the components work.

**Circuit Simulation:** You will use computer packages to simulate circuits, allowing designs to be tested.

**Circuit Construction:** Using soldering, you will construct your own circuits.

### What kind of things will you be doing?

The course will be taught through a variety of experiences. There will be many opportunities for practical experience through the construction of circuits from pre-fabricated electronics boards and from individual circuit components. There will also be opportunities for developing the skills required to test circuits using digital meters.

### How will you be assessed?

Assessment will be through a combination of written reports, answers to written questions and teacher observation. At National 5 level there is an end of course exam..

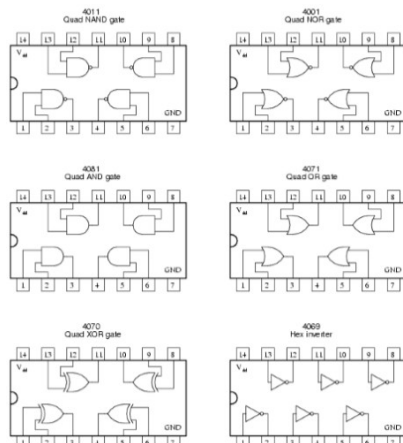
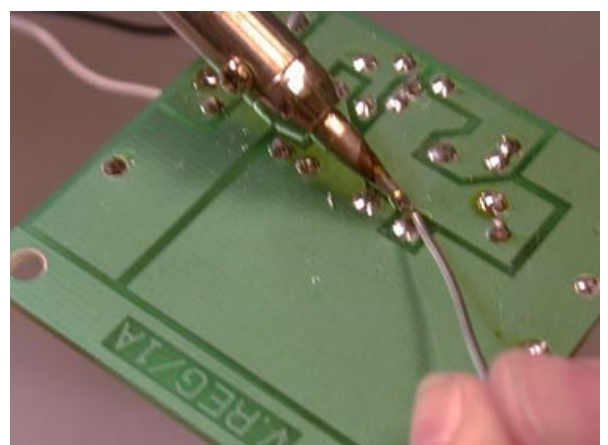

### Entry Requirements

This course builds on learning from National 3 or National 4 Physics however neither is necessary.



# Practical Metalwork: National 4/5

## Why Study Practical Metalwork?

The Course provides opportunities for learners to gain a range of practical metalworking skills and to use a variety of tools, equipment and materials. It allows them to plan activities through to the completion of a finished product in metal.

This course gives you:

- skills in metalworking techniques
- skills in measuring and marking out metal sections and sheet materials
- safe working practices in workshop environments
- practical creativity and problem-solving skills
- knowledge of sustainability issues in a practical metalworking context



	<b>National 4/5 Practical Metalwork</b>
<b>Entry Point</b>	No previous experience required.
<b>Course Detail</b>	<p><b>Bench Skills</b></p> <p>This Unit helps learners develop a range of metalworking hand tool skills including simple bench-fitting work, basic sheet-metal work and simple measuring and marking out work. The ability to read and interpret simple drawings and diagrams is developed in this Unit</p> <p><b>Machine Processes</b></p> <p>This Unit helps learners build measuring and marking out skills and to develop skills in using common metalwork machines, equipment and related processes. Learners will work with an appropriate range of metals.</p> <p><b>Fabrication and Thermal Joining</b></p> <p>This Unit helps learners develop skills in fabrication, forming and joining of simple metalwork components. Learners will develop skills in thermal joining techniques. They will also build skills in measuring and marking out.</p> <p>In each of the Units above, learners will develop an appreciation of safe working practices in a workshop environment. They will also gain an understanding of sustainability issues in a practical metalworking context.</p>
<b>Course Assessment</b>	Final practical project covering all elements which forms the Added Value Unit (AVU) Assessment for National 4. At National 5 there is a final project (70%) and written theory exam (30%).

# Practical Woodwork: National 4/5

## Why study practical woodwork?

A practical, workshop based course with no design content. You will make products in wood from given working drawings, learning skills while working safely.



This course gives you:

- The experience and appreciation of materials and craft skills
- Practical experience if you are planning to go into the engineering or construction industry

	<b>National 4/5 Practical Woodworking</b>
<b>Entry Point</b>	No previous experience required.
<b>Course Detail</b>	<p><b>Flat-frame Construction Unit</b></p> <ul style="list-style-type: none"> <li>• develop skills in the use of woodworking tools and in making woodworking joints and assemblies commonly used in flat-frame joinery</li> <li>• develop the ability to read and use drawings and diagrams depicting both familiar and unfamiliar woodwork tasks.</li> </ul> <p><b>Carcase Construction Unit</b></p> <ul style="list-style-type: none"> <li>• develop skills in making woodworking joints and assemblies commonly used in carcass construction</li> <li>• working with manufactured board or with frames and panels</li> <li>• using working drawings or diagrams, including unfamiliar contexts that require some interpretation on the part of the learner</li> </ul> <p><b>Machining and Finishing Unit</b></p> <ul style="list-style-type: none"> <li>• developing skills in using common machine and power tools</li> <li>• developing skills in a variety of woodworking surface preparations and finishing techniques.</li> </ul>
<b>Course Assessment</b>	Final practical project covering all elements which forms the Added Value Unit (AVU) Assessment for National 4. At National 5 there is a final project (70%) and written theory exam (30%).

# Religious, Moral and Philosophical Studies (RMPS Higher)

## Why Study RMPS?

The Course aims:

The main aims of the Course are to enable learners to develop:

- The ability to analyse religious, moral and philosophical questions and their impact
- The skill of reflection in relation to religious, moral and philosophical questions
- The ability to express reasoned views on questions and their impact
- The skills required to investigate religious, moral and philosophical questions and responses
- The ability to evaluate religious and non-religious beliefs

What Courses Are On Offer?

<b>Higher RMPS</b>	
<b>Entry Point</b>	<i>National 5 in English or a Social Subject</i>
<b>Course Details</b>	<p>Courses are explored through the following areas of study:</p> <p><b>World Religion</b> Learners will develop skills to interpret and comment on the meaning and context of sources related to Christianity. They will develop in-depth factual and abstract knowledge and understanding of the impact and significance of religion today through studying beliefs and practices and the contribution these make to the lives of followers.</p> <p><b>Morality and Belief</b> Learners will develop skills to evaluate and express detailed, reasoned and well-structured views about contemporary moral questions and responses on Religion and Justice.</p> <p><b>Religious and Philosophical Questions</b> Learners will develop skills to critically analyse religious and philosophical questions and responses on the existence of God.</p> <p>Successful completion of this course could support progression towards:</p> <ul style="list-style-type: none"> <li>• MA Divinity, MA Theology, MA Religious Studies</li> <li>• Employment in areas such as Law, Social Work, Broadcasting and Media, Teaching and Healthcare</li> </ul>
<b>Assessment</b>	The course assessment consists of a question paper and an assignment. Both are marked by the SQA and will be graded A to D.

# Skills for Work: Laboratory Science; National 5

## Why Choose Laboratory Science?

Scotland has a substantial number of scientific companies, either performing analytical work or manufacturing. Additionally, scientific services are required in hospitals and schools.

National 5 Skills for Work: Laboratory Science is an introductory qualification, providing pupils with a broad experiential introduction to laboratory science. You would explore a variety of industries and services, and career opportunities, in science laboratories locally, nationally, and globally.

You would develop the basic practical skills and knowledge needed for working in a laboratory: measuring, weighing and preparing compounds and solutions; and health and safety requirements. Practical skills in microbiology, measuring radioactivity, chemical handling and laboratory instrumentation will be developed.

You would work with others to produce a plan to undertake a practical investigation to test scientific hypotheses. This will also involve reporting of the results, conclusions and evaluations of the investigation.

Throughout all units the course emphasises the employability skills and attitudes valued by employers which will help to prepare you for the workplace. You would also review their own employability skills, and will seek feedback from others on their strengths and weaknesses.



## How Is The Course Organised?

The course is divided into four units.

- Careers using Laboratory Science
- Working in a Laboratory
- Practical Skills
- Practical Investigation



## What kind of things will you be doing?

Throughout the course, assessment is based on both written and practical tasks. You will be assessed through:

- Writing a CV
- Preparing solutions
- Writing risk assessments
- Growing microbial cultures
- Measuring radioactivity
- Carrying out an investigation
- Producing an investigation report.

## Where would National 5 Laboratory Science lead?

This course progresses to National Progression Awards, Professional Development Awards or Foundation Apprenticeships in the scientific industries.

## Entry Requirements

This is a National 5 level course so the entry requirement is National 4 level in Biology, Chemistry or Physics.

# Skills for Work: Travel & Tourism—National 4/5

## Why Study Travel and Tourism?

- If you are interested in developing the skills to work in the travel and tourism industry this will be a valuable course for you to study.
- If you are interested in a career which is customer focussed then the skills you develop in this course will be valuable and can be transferred to lots of other jobs and careers.
- If you are interested in travel this course introduces you to a range of destinations in Scotland, the rest of the UK, Europe and Worldwide.

	<b>Travel and Tourism: SCQF Level 4/5</b>
<b>Entry Requirements</b>	Interest in Travel and Tourism related subjects
<b>Course Outline &amp; Units</b>	<p>The National 4 and 5 Skills for Work: Travel and Tourism Course is an introductory qualification in travel and tourism. It develops the skills, knowledge and attitudes needed for work in the travel and tourism industry.</p> <p><b>Learners will develop:</b></p> <ul style="list-style-type: none"> <li>• skills to become effective job-seekers and employees</li> <li>• skills to deal effectively with all aspects of customer care and customer service in travel and tourism</li> <li>• the product knowledge and skills to deal effectively with customer enquiries in relation to travel and tourism in Scotland, the rest of the United Kingdom and worldwide</li> </ul> <p>The four units studied and assessed are:</p> <ul style="list-style-type: none"> <li>• Scotland (destinations)</li> <li>• UK and Worldwide (destinations)</li> <li>• Employability</li> <li>• Customer Service</li> </ul> <p>Learners will undertake a wide range of independent research in class, be given the opportunity to make industry-related visits and to participate in practical activities.</p>
<b>Assessment</b>	<p>All units are internally assessed on a pass/fail basis.</p> <p><b>There is no final exam for either National 4 or National 5.</b></p>

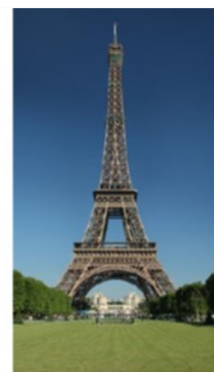

# ***JET ACADEMY—Your Pathway Your Future***

THE JET ACADEMY is a work based learning programme offering pupils in their senior phase the opportunity to work towards educational qualifications, gain work experience and learn the skills employers are looking for through an extended work placement.

**The JET Academy provides two placement options for senior phase pupils.**

## **1. JET**

The JET Programme has run successfully for many years across Edinburgh. Pupils are matched to a workplace where they undertake a full day work placement with an employer in a sector of their choice. The school timetable will be adjusted to accommodate this placement. Pupils will work towards an SQA Employability Award at SCQF Level 4.

Work Placement Coordinators work closely with pupils and schools to monitor progress and ensure that the placement is positive for pupils and employers.

There is scope for pupils to gain additional qualifications through the School College partnership and flexibility in when they attend their work placement.

## **PROGRESSIONS FROM JET**

Possible progressions are: Stay at school, Modern Apprenticeship, employment or College.

## **2. JET +**

If you are a winter leaver you can apply for JET+. The programme is designed for young people who are focused on gaining practical experience from a full-time work placement. The pupils will have regular contact with a Work Placement Coordinator who will provide support throughout their placement. During the JET+ programme, young people will meet with employers, training providers, colleges and SDS staff in order to discuss pathways. Nearing the end of the programme, young people will be advised on the options available to them and Work Placement Coordinators will support with next steps in securing a positive destination on leaving school.

There is scope for pupils to gain additional qualifications.

## **PROGRESSIONS FROM JET +**

JET + has 100% success rate in progressing young people into a positive destination. Progression routes include employment, college, modern apprenticeships and training.

**For more information please speak to your Pupil Support Leader.**



**JET ACADEMY**  
13 NEWTOFT STREET  
EDINBURGH  
EH17 8RG  
T: 0131 529 6900  
E: [JET.Info@edinburgh.gov.uk](mailto:JET.Info@edinburgh.gov.uk)