



St Augustine's RC High School



Curriculum Guide

S3 & S4

For Pupils and Parents

2024 - 2025



St Augustine's RC High School
Broomhouse Road
Edinburgh
EH12 9AD

Tel 0131 334 6801

Fax 0737 334 7329

Email admin@st-augustines.edin.sch.uk

Website staugustinesrchs.uk

This guide is written with S3 as our target audience.
We hope that parents will find it useful too.

Introduction

This booklet will guide pupil through the process of choosing subjects. It will discuss a variety of areas and also provide subject specific information so that pupils can make good, informed decisions.

Pathways

We are all different and the next few years will see us all following different pathways in our learning.

Pathway 1 - Studying till the end of S4 with a view to going to college or undertaking a modern apprenticeship or employment

Pathway 2 - Studying till the end of S5 with a view to going to college or undertaking a modern apprenticeship or employment

Pathway 3 - Studying till the end of S6 with a view to going to university

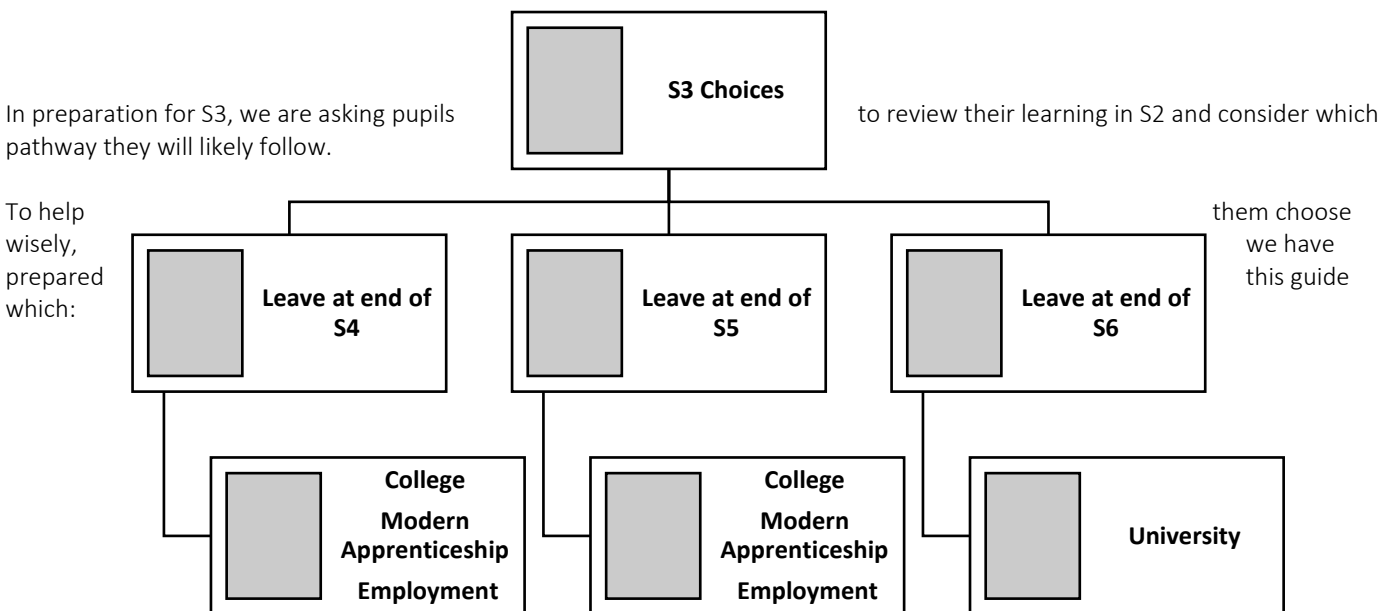

- Outlines what to consider when making subject choices
- Tells you how we will help
- Gives you more information on the S3 curriculum.

At the **S2 Parents' Consultation Evening**, parents/carers will be able to discuss the tracking report with teachers and identify strengths and development areas.

In addition, Pupil Support Leaders will support pupils and families with lots of advice and an opportunity to discuss learning choices for S3.

Subject Choice

Free Choice/Selection

Pupils will have free choice and can choose any subject on offer. However, there are some important points to consider.

- Some subject choices may not be possible (oversubscription/clashes with other subjects/lack of numbers).
- We encourage Pupils and Parents/Carers to follow staff advice when selecting particular subjects. For example, during Parents Evening or Tracking Reports.
- Prior learning in a subject could be taken in to consideration if necessary.
- Pupils and Parents/Carers should refer to the Learner Pathways Information booklet and Parent Powerpoint Presentation for further details.
- Pupils should also think about their career path and what they would like to do when they leave school so that they understand what subjects they should be taking that will support this career choice.

Compulsory Subjects

Below are the subjects that all pupils will have on their timetable.

- English (4 periods per week)
- Mathematics (4 periods per week)
- Religious Education (2 periods per week)
- Physical Education (2 periods per week)
- Personal Social Education (1 period per week)

In addition, **five further subjects** must be chosen from the options available. Pupils should also select 2 reserve choices. This is in case some of their subject choices are not possible.

Pupils will be asked to choose subjects by preference. For example, if they are very keen to take French, this should be one of their first choices.

Please Note the Following:

- Pupils are making their choices for **S3 and S4**. Pupils will not be able to change their choices in S4. The subjects chosen will be the subjects that pupils sit SQA formal assessments in.
- S4 is just the start of your journey through the SQA qualifications framework. You have three school years to help you make your mind up about where you want to go. If you can't study all of the things you want to in S3 and S4, you can pick them up in S5 or S6.
- It is important to choose the correct subject. Re-coursing is very difficult to do.

Course choice form can be found at the end of this booklet.

Personalisation and Choice

Pupils **should** choose a subject because:-

- They like it
- They are good at it
- It could lead to a possible career in the future

Pupils **should not** to choose a subject are:-

- Because they can't think of anything else to do
- Because that is what their friends are doing
- Because they like a particular teacher (there is no guarantee that they will have the same one)

The Curriculum

In S3 and S4, subjects are grouped into **Curricular Areas** to ensure breadth of learning.

These Curricular Areas are:-

<i>Curricular Areas</i>	<i>Subjects</i>
English and Literacy	English or ESOL
Languages	French and Spanish
Mathematics and Numeracy	Mathematics
Religious & Moral Education	Religious Education
Health and Well-Being	Physical Education, Practical Cookery Personal & Social Education
Science	Biology, Chemistry, Physics, Science & Health
Social Studies	Geography, History, Modern Studies, Business Education
Technology	Administration & IT , Computing Science, Craft & Design, Home Economics, Design & Manufacture , Practical Woodworking
Expressive Arts	Art, Drama, Media, Music, Music Technology, Media, Creative Industries
Wider Achievement	Princes Trust, Duke of Edinburgh

S3 and S4 Curriculum

In summary the S3 and S4 Curriculum looks like this.

Religious Education	2 periods per week
Physical Education	2 periods per week
Personal and Social Education	1 period per week
Maths	4 periods per week
English / ESOL	4 periods per week
Choice 1	4 periods per week
Choice 2	4 periods per week
Choice 3	4 periods per week
Choice 4	4 periods per week
Choice 5	4 periods per week
Total	33 periods per week

Support for Pupils and Parents/Carers

There is a range of support for pupils to help guide them to choosing the right subjects for the right reasons.

- Pupil Support Leader
- Careers Advisor
- Year Head
- Subject Specialist Teacher
- Support for Learning & Wellbeing Hub (when appropriate)

Parents/Carers are encouraged to attend Parents Evenings and attend the Curriculum Information sessions to help gather more information on course choice. Information for these events will be communicated with parents/Carers each year.

Courses

Administration – S3

What are the aims of the course?

The course aims to further develop your ICT skills and to build on the skills you have been learning in S1/2.

Administration focuses on the ways in which modern businesses use ICT to go about their daily work. The Administration course will also introduce you to how businesses get their employees to be more organised!

How is the course assessed?

The course will be assessed by end of unit tests and observation.

Homework

Homework will be given for each unit. This will be based on the 'theory' parts of the course covered that week in class, for example Meetings and Health and Safety.



What will I be doing in class?

You will be working as a trainee for a business. You will be given an 'action plan' and you will be expected to treat the classroom like a real business.

You will be building on the ICT skills you used in S2, using Microsoft Software

What topics will I be studying?

THEORY

- The role of the Admin Assistant
- Working practices
- Office environment and security
- Health and safety legislations

PRACTICAL

- E-touch typing
- MS word/Excel/Access/Powerpoint
- Pupils will develop ICT skills to facilitate the transfer of ICT between classrooms and the world of work.

Pupils will work on tasks based on a simulation or real workplace and be expected to select appropriate software to carry out tasks which support business and entrepreneurial activities.

Administration & IT – S4

The Administration and IT course is set out to develop the learners Administration and IT skills and, ultimately, enable them to contribute to the effective functioning of organisations. Administration is a growing sector which cuts across the entire economy and offers wide-ranging employment opportunities. Moreover, administrative and IT skills have extensive application not only in employment but also in other walks of life.



	National 4	National 5
Content	<p>Administrative Practices</p> <ul style="list-style-type: none"> • Legislation affecting employees • Good customer care and skills • Qualities and attributes required of administrators • Skills to organise and support small-scale events. <p>IT Solutions for Administrators Learners will use the following applications:</p> <ul style="list-style-type: none"> • Word processing • Powerpoint • Spreadsheets • Databases • DTP <p>Communication in Administration Learners will develop:</p> <ul style="list-style-type: none"> • An ability to use appropriate methods for gathering information • Produce this information showing awareness of its context, purpose and audience <p>Added Value Unit Students will use the skills and knowledge they have learnt throughout the course to produce a practical Administration and IT assignment.</p>	<p>The course has two areas of study:</p> <p>Administrative Theory in the Workplace</p> <p>Learners are introduced to the responsibilities of organisations, the skills/qualities and tasks (duties) of the administrative support function, and the impact of these in the workplace.</p> <p>IT Applications</p> <p>This area contains a significant practical component. Learners develop skills in IT, problem-solving, organising, and managing information. They select IT applications to create and edit business documents, gather and share information, and develop skills to communicate information. They will develop skills in using:-</p> <ul style="list-style-type: none"> • Spreadsheets • Databases • Word-processing • Desktop publishing • Presentations • Electronic communication
Assessment	Internal	External assessment 42% Course assignment 58%
Minimum	<ul style="list-style-type: none"> • Level 3 Administration and IT or relevant component Units 	<ul style="list-style-type: none"> • National 4 or Level 4 Administration and IT or relevant component units

Entry Requirements	<ul style="list-style-type: none">• Level 3 Business or relevant component Units	<ul style="list-style-type: none">• National 4 or Level 4 Business and IT or relevant component units
Homework	Theory homework per unit.	Theory homework per unit.

Why Choose Art & Design?

Art & Design gives you the opportunity to:

- take part in design and expressive activities
- develop creative design & expressive skills
- appreciate social & cultural factors that influence design and expressive practice
- use a variety of art media and techniques developing work in 2D and 3D
- study design and expressive art techniques, genres, and the impact of creative choices on society

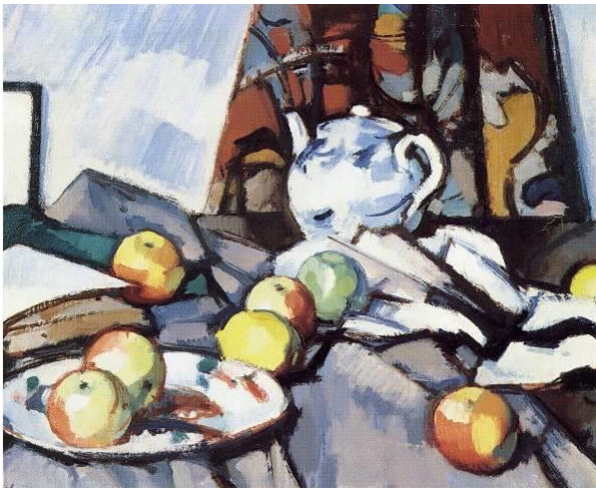

How is the course organised?

You will work on two main projects; a Design folio and an Expressive folio. For each you will produce a folder of practical and critical work. You will use a range of art media and techniques including paint, print and clay. In each unit you will study selected designers and artists gaining knowledge and understanding of the factors influencing them.

How are you assessed?

By the end of S4 you will have completed two units and projects

Unit 1: Design Activity

- designers and design techniques
- factors influencing designer's work
- facts and opinions about designer's work

- produce creative design ideas using various design materials

Unit 2: Expressive Activity

- artists and techniques
- factors influencing artist's work
- facts and opinions about artist's work
- produce creative expressive work using various materials and techniques
- evaluate skills in the creative process

Project work

- produce an expressive art piece
- produce a graphic design
- reflect on the visual qualities and effectiveness of the outcomes

How is the course assessed?

At the end of S4, students working at National 5 level will sit an SQA exam and gain a course award.

Students working at National 4 level will gain a course award based on work produced in school.

Career Opportunities

As well as being a desirable qualification for some college and university courses, Art & Design is essential for many careers and very useful for a great many more.

Typical careers include:

- Architect
- Product designer
- Graphic designer
- Teacher
- Web page designer
- Make-up artist
- Fashion designer

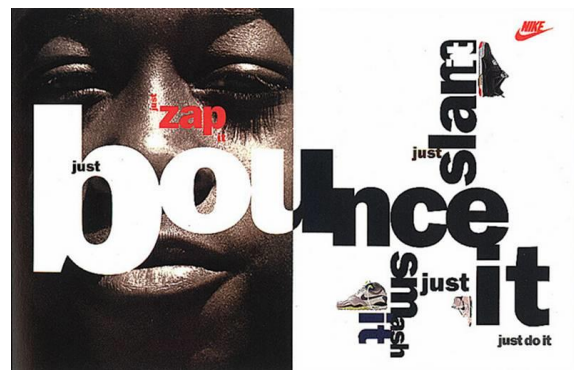

Biology – S3 & S4

Why Choose Biology?

- Are you intrigued with the incredible variety of organisms that inhabit our planet?
- Can our global life-support system continue supporting an increasing human population?
- What lies ahead for the future of genetic engineering?
- What are clones and *transgenic* animals?



Biology is the scientific exploration of the vast and diverse world of living organisms; an exploration that will expand enormously in the 21st century. The study of Biology has an immediate relevance to our daily lives. It is important for everyone to develop an informed sense of how we may continue to fit into the complex ecology of our planet. Some of the greatest engineering feats of the future are likely to involve bioengineering projects and Biology.

Where Could a Biology Qualification Lead?

Biology is a relevant and often essential qualification in the following areas of work:

nursing; physiotherapy; radiotherapy; medicine; veterinary science; dentistry; laboratory technology; animal and plant breeding; psychology; pharmaceutical, horticultural, agricultural, environmental, water control, waste management, food, drink and forestry industries. Biology is a useful science in many other careers.

Biology is a good choice as it combines very well with both Physics and Chemistry.

How is the course organised?

The course will be organised into 3 broad, general units. They cover:

- Cell Biology
- Multicellular Organisms
- Life on Earth

Within the three units pupils will undertake the outcomes at either National 3, National 4, or National 5 level.

What kind of things will you be doing?



Some of the Biology topics covered are human physiology, ecosystems, genetics, respiration, photosynthesis and enzymes. These taught through a variety of experiences such as lab work, field work, microscope work, computer simulations and research. You will learn collaboratively, working with others to develop your understanding. There will be opportunities to participate in educational excursions and visits eg to the Royal Botanic Garden.

How will you be assessed?

Assessment will be through a combination of ongoing assessment and end of unit tests and will be undertaken through teacher, self and peer assessment. Assessment will be undertaken in line with National Strategies, assessing both your understanding of Biology and the Skills for Learning, Life and Work.

Homework Requirements

Homework will be set weekly to help you develop your understanding. Homework will take a variety of forms, including research, problem solving questions, communication tasks and revision for tests.



What are the aims of the course?

To develop your understanding of the current business world and to introduce you to how businesses are organised. You will learn how real businesses work and you use the Internet to look at these businesses in action.

How is the course assessed?

The course is assessed through end of unit assessment and ongoing observation.

Minimum Entry Requirements are:

A general interest in current affairs would be an advantage. **You will be expected to work in teams and take on extra work outside normal school hours.**

Have you the enthusiasm to work in business?

Have you got the skills to work in a team?

Homework

This will be issued weekly. Questions will be based on the theory covered in class that week. You will also be expected to watch the news or read a newspaper to keep up with current affairs.

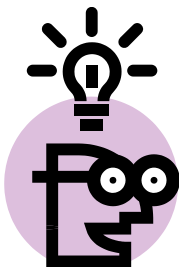

A-Bay.com

What topics will I be studying?

Some of the topics you will look at include:

- The role of operations
- Needs and wants
- Types of business
- Stakeholders
- Enterprise
- Business environment
- Success/failure of businesses
- Business ethics
- Finance
- Business and ICT
- Fair trade
- Human resources management
- The role of the Marketing Department

Will the course teach me how to run a business?

Yes and No!

The course will give you a flavour as to what different types of business do. There are a great number of skills you will learn in the course; for example, problem solving and using your ICT skills.

Related Careers

- Setting up your own business
- Marketing/HR/Finance manager
- Business Lawyer



Business Management – S4

Business Management introduces students to the dynamic, changing, competitive and economic environment of industry and commerce. It helps to develop skills in communicating and presenting business-related information, in a wide variety of formats to the various stakeholders of an organisation. These skills not only give students an understanding of their future place in the world of work, but as real-life business contexts are widely used, students gain a greater understanding of the economic and financial environment in which businesses operate.



	National 4	National 5
Content	<p>Business in Action</p> <ul style="list-style-type: none"> • How small businesses operate • Satisfying Customer Needs • Different functional departments within businesses. <p>Influences on Business</p> <ul style="list-style-type: none"> • Stakeholders • Internal influences • External influences <p>Added Value Unit Students will use the skills and knowledge they have learnt throughout the course to produce an assignment.</p>	<p>The course has five areas of study:</p> <p>Learners will develop skills, knowledge and understanding in the following areas:</p> <p>Understanding Business Enterprise and the role of different types of business organisations in society. Internal and external environments in which organisations operate, and the role of stakeholders in business.</p> <p>Management of Marketing The importance to organisations of having effective marketing systems. The processes and procedures organisations use to maintain competitiveness, and how marketing can be used to communicate effectively with consumers, maximising customer satisfaction.</p> <p>Management of Operations The importance to organisations of having effective operations systems. The processes and procedures used to maintain quality through the effective management of suppliers, inventory, and methods of production in an ethical manner.</p> <p>Management of People The issues facing organisations when managing people. The theories, concepts and processes relating to human resource management, and how employees contribute to the success of organisations.</p> <p>Management of Finance The issues facing organisations when managing finance. The basic theories, concepts and processes relating to financial aspects of business, when interpreting information to solve financial problems.</p>
Assessment	Internal	75% External assessment 25% Internal assessment
Minimum Entry Requirements	Level 3 Business or relevant component units.	National 4 or Level 4 Business course or relevant component units.
Homework	Theory homework every 1 to 2 weeks.	Theory homework every week.

Chemistry – S3 & S4

Why Choose Chemistry?

The chemistry course in S3-4 is designed to help you understand the ideas and concepts which make sense of the everyday importance of chemistry in the modern world.

Studying Chemistry at National 5 level in S4 will lead to a solid grounding in the knowledge and skills you need to progress through the subject at Higher and Advanced Higher level.

You will be taught using experimental work which is an integral part of the course, helping to develop understanding and knowledge as well as your practical skills.

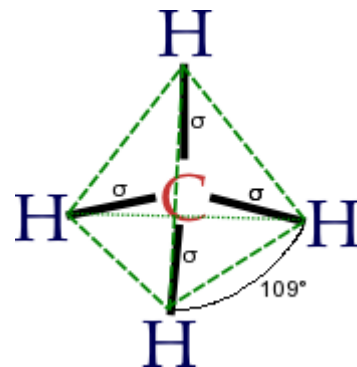

Where Could a Chemistry Qualification Lead?



Chemistry is the central science and a good understanding of chemistry will be a great advantage to you if you have an interest in a career in any science-based field.

(Chemistry combines well with both Biology and Physics.)

Examples of careers involving Chemistry are forensic scientist, environmental scientist, physiotherapist, doctor, cosmetic scientist, food scientist, nurse, dentist, food scientist, nuclear scientist, vet, molecular biologist, chemical engineer, science teacher....

How is the course organised?

The course will be organised into 3 broad, general units. They cover:

- Chemical Changes and Structure
- Nature's Chemistry
- Chemistry in Society

Within the three units pupils will undertake the outcomes at either National 3, National 4 or National 5 level.

What kind of things will you be doing?

You will develop skills and an awareness of ethical and environmental issues in a local and worldwide context and gain an understanding in how chemistry is involved in the cause, effect and resolution of these issues. Chemists will develop analytical skills through investigating new materials and energy sources and learn about the application of chemistry through everyday products such as cosmetics, fuel and food.

How will you be assessed?

Assessment for Chemistry involves 3 elements:

- end of unit assessments involving knowledge and skills questions
- assignment where pupils will perform practical work and produce a full written report. For National 5 this is written under exam conditions
- full course assessment for National 5

Homework Requirements

Homework will be set regularly to help you develop your understanding. Homework will take a variety of forms, including research, problem solving questions, communication tasks and revision for tests.

Why Choose Computing Science?

This course prepares young people for the challenges of rapidly changing digital technologies. In a practical and investigative way, it provides an understanding of the world through computational thinking and of computing technology. It also promotes problem solving by designing and developing computing solutions.

It develops a broad-based knowledge that establishes a foundation for further specialised study and careers including Robotics, Software Engineering, Medical Imaging, Web Design, Entertainment Technologies, Business Information Systems, Networking, Computer Gaming and Digital Forensics.

How is the course organised?

This practical course is organised in units with a blend of independent, paired and group work

What kind of things will you be doing?

- Graphics- Create complex images using bitmap and vector graphics
- Programming- Design & develop your own programs using Scratch and Python
- Digital Products- Create, collaborate and publish digital content online
- Digital Solutions- Build advanced websites using HTML/CSS and query database systems using SQL
- Cyber Resilience- Understand how to protect new technologies and explore the impact of cybercrime
- Games Development- create computer games using GameMaker software

- Emerging Technologies- Explore Virtual Reality and Artificial Intelligence



How are you assessed?

An electronic portfolio is built up over each unit relating to practical evidence. Learner-led presentations and demonstrations will provide class discussion. A combination of peer and self-assessment and ongoing observation will also be used. Progress checks will assess learners' knowledge and understanding.

Homework requirements

Each unit will have one or two set homework tasks.

Computing Science – S4

Computing Science is vital to everyday life; it shapes the world in which we live and its future. These courses highlight how computing professionals are problem-solvers and designers, and the far-reaching impact of information technology on our environment and society. They help learners to understand computational processes and thinking. They are designed for learners who are considering further study or a career in computing science including Robotics, Software Engineering, Medical Imaging, Web Design, Entertainment Technologies, Networking, Business Information Systems, Computer Gaming and Digital Forensics. They also develop skills for all learners which can be transferred to any employment area.



National 4	National 5
	The course has four areas of study:
<p>Software Design & Development Learners will develop basic computational thinking and programming skills by creating programs in LiveCode and explaining how these programs work.</p>	<p>Software design and development Learners will develop skills through a range of practical tasks using appropriate software development environments. This develops their programming and computational-thinking skills by implementing practical solutions.</p>
<p>Information System Design & Development Learners will design and develop information systems through a range of practical and investigative tasks. Learners will implement practical solutions using a range of development tools, eg Database, Multimedia and Web Creation.</p>	<p>Computer systems Learners will develop an understanding of how data and instructions are stored in binary form and basic computer architecture. They gain an awareness of the environmental impact of computing systems and security precautions that can be taken to protect computer systems.</p>
<p>Added Value Unit Learners will create a digital solution which will draw on and apply skills and knowledge of software and information systems design and development.</p>	<p>Database design and development Learners will develop skills in database design and development, through a range of practical tasks. This allows learners to apply computational-thinking skills using a range of development tools such as SQL.</p>
	<p>Web design and development Learners will develop skills in web design and development, through a range of practical tasks. This allows learners to analyse, design, implement, test and evaluate practical solutions to web-based problems, using a range of development tools such as HTML, CSS and Javascript.</p>
<p>Assessment Internal</p>	<p>Assessment External assessment 69% Course Assignment 31%</p>
<p>Entry Requirements Level 3 Computing Science</p>	<p>Entry Requirements National 4 or Level 4 Computing Science</p>
<p>Homework Once a week</p>	<p>Homework Once a week</p>

Creative Industries



Why Choose Creative Industries

Creative Industries is a skills for work course – which means it is continuously assessed throughout the course rather than sitting an exam at the end of S4. Creative Industries offers the opportunity to explore and develop your skills and talents through a variety of pathways and courses offered within the Performing Arts Faculty. This means if you choose a Performing Arts subject – Drama (Acting), Drama (Production), Media, Music and Music Technology – you can actually achieve TWO qualifications.

Creative Industries teaches you:-

- Planning and time management
- Group work
- Leadership
- Manage your own learning
- Problem Solving
- Presenting and Performance Skills
- Film making

How is the course organised?

Through projects in your chosen Performing Arts subjects you will respond to Creative Briefs, set yourself targets and evaluate your own creative skills and abilities.



You will not see an option on your course choice for Creative Industries. When you choose ANY of the Performing Arts Subjects you will also cover the Creative Industries outcomes.

Design & Manufacture – S3 & S4

Why Choose Design & Manufacture?

The National 4/5 course will give you an opportunity to develop more advanced designing and making skills. You will work on more complex and exciting design problems and learn more about commercial product design, industrial processes and their impact on society.

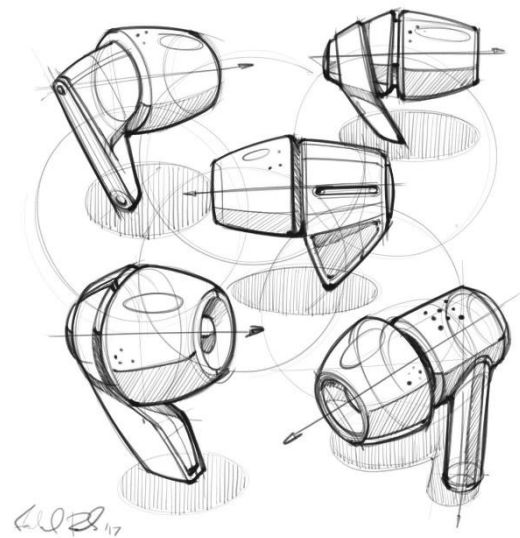

How is the course organised?

You will work on a series of product design assignments. For each project you will produce a design folio then make the product. You will use a wider range of materials including wood, metal and plastics. In each project you will study design theory and gain knowledge of tools, materials, school workshop processes and industrial processes.

How are you assessed?

By the end of S4 you will have completed two Units and projects:

Unit 1: Design

Assessment will be based on the design folios and design theory class tests.

Unit 2: Materials & Manufacture

Assessment will be based on the manufactured items as well as knowledge of materials & processes class tests.

Project work

Assessment will be based on a design and manufacture project that students choose from a bank of options.

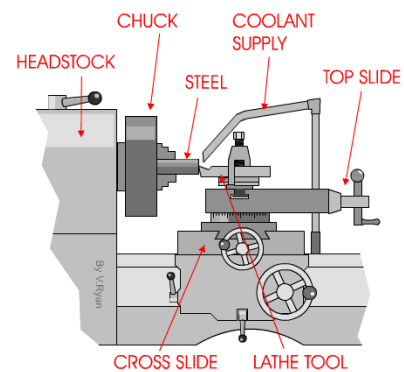

How is the Course assessed?

At the end of S4, students working at National 5 level will sit an SQA exam and gain a course award. Students working at National 4 level will gain a course award based on work produced in school.



Career Opportunities

As well as teaching you useful life skills Design & Manufacture can lead to college and university courses. Design & Manufacture is essential for some careers and very useful for a great many more. Typical careers include:

- product design
- furniture design
- industrial design
- engineering
- technician services
- craft trades

Drama

Why Choose Drama?



Drama develops your skills and abilities in both Acting and Production. The Drama course enables you to develop skills for learning, life and work. You will be encouraged to think both critically and creatively in addition to developing both group work and leadership skills, which are all essential for a life beyond school.

Drama teaches you:-

- Present yourself and ideas
- Work as part of a group
- Take responsibility for your learning
- Think critically and creatively
- Leadership skills

How is the course organised?

The course is organised into units. Some units may last for only one lesson. Others might last for two or three weeks.

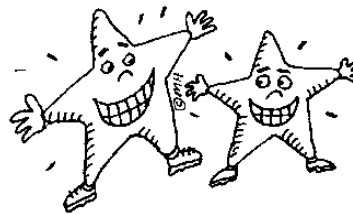

What kind of things will you be doing?

You will do a variety of projects throughout S3 and develop a range of skills – characterisation, script work, mask and physical theatre and design tasks. There will be opportunities to perform both in and outside of school for different audiences eg Performing for the public as part of the Edinburgh Fringe. Or for younger year groups you will be involved in all aspects of creating a performance as an Actor, and in Production roles; Lighting, Sound, costume, props, make-up and set design.

How are you assessed?

Throughout S3 your teacher will assess your progress through observational checklists, peer evaluation and folio tasks. You will receive regular feedback so you know how to improve your work.

Homework Requirements

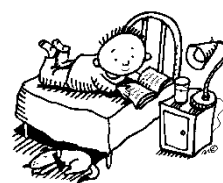

You will be set weekly homework – learning Drama terminology, production design tasks, learning lines and cues, developing texts and conducting research.

Homework is needed to prepare for practical group work and it is an essential part of the course.

Drama - S4

About the Course

The course uses an integrated approach to learning which develops practical skills as well as knowledge and understanding of drama. As learners develop their creating skills, they will also learn how to use a range of drama skills. They will experiment with presenting through portrayal of character and by using a range of production skills.



The course is split into three sections.

- **Drama Skills** challenges pupils to work collaboratively to explore a theme/issue, employ research skills and the drama process to present a drama presentation.
- **Theatre Production Skills** allows pupils to learn about key theatre production roles and how different practitioners (eg lighting designer, stage manager etc.) work together to produce a successful performance.
- The **Added Value** unit challenges the pupils to use the skills developed throughout the course to produce a theatre performance to a professional level.

The **National 5 course** is similar to **National 4** but a higher and more creative standard of work is expected.

Assessment

Pupils will complete internal assessments for each section – both extended written responses and practical assessments must be passed in order to complete the course.

Teachers will complete Observational Checklists throughout and pupils will maintain logbooks which will include personal/group research, design plans, and other tasks to support learning and teaching.

Teachers will regularly meet with pupils individually to provide meaningful feedback and target set for the future.



Exam Information

As part of the third section, **National 4** students will create, present and evaluate a drama demonstrating the skills they have acquired throughout the course. This will be internally assessed.

National 5 students will also create a final performance for assessment but will also have to sit a written question paper which will be externally assessed. The course is broken down as 60% for a final practical assessment and 40% for the written exam.

- For the practical assessment, pupils will choose a production role from Acting, Directing or Design and will take responsibility for this area for a final performance.
- In May, pupils will complete a written exam which challenges pupil's knowledge and understanding of drama, ability to self-evaluate and respond to an unseen stimulus

Homework

Regular homework will be issued. This could be in a range of forms from written, personal research, completion of logbooks or revising for unit tests. However, homework may take the form of learning lines from a script or preparing for a specific production role. Pupils must understand that working at home is an essential element of the course and is key to success at both National levels.

Possible Careers

In addition to obvious careers in the entertainment industry, the course design allows pupils to develop a broad range of skills for learning, life and work such as personal learning skills, thinking skills. The course encourages self-discipline, perseverance, planning and the ability to identify areas for improvement. All of these are valuable skills which attract prospective employers.

Duke of Edinburgh

Why choose Duke of Edinburgh?



A life-changing experience. A fun time with friends. An opportunity to discover new interests and talents. A tool to develop essential skills for life and work. A recognised mark of achievement; respected by employers.

14-24 year-olds can do a DofE programme at one of three progressive levels which, when successfully completed, leads to a Bronze, Silver or Gold Duke of Edinburgh's Award.

Any young person can do their DofE – regardless of ability, gender, background or location. Achieving an Award isn't a competition or about being first. It's all about setting personal challenges and pushing personal boundaries.

Through a DofE programme young people have fun, make friends, improve their self-esteem and build confidence. They gain essential skills and attributes for work and life such as resilience, problem-solving, team-working, communication and drive, enhancing CVs and university and job applications.

Through our DofE programme, our young people will gain the Award at Bronze and Silver level and units in Practical woodwork as well as Paddle sports Qualifications and First Aid certificate.



Why choose English?

Clear and effective communication skills are imperative for your success in learning, work and life. All careers require the skills that you will learn in your English classes. You will develop your skills of Reading, Writing, Listening and Talk in a variety of engaging ways.



How is the course organised?

You will develop your skills through the broad general education course. Every S3 student will study:

- Creative writing
- Close reading skills
- Discursive writing
- Talk and Listening skills
- A range of literature from different genres

You will build on the skills that you develop throughout the year ensuring that you are progressing properly and preparing for the move to National exams.

What kind of things will you be doing?

You will do a variety of tasks for different purposes. You will be asked to work cooperatively in groups undertaking different roles in order to achieve the required outcome. This will be supported by solo and paired work. You can also expect to be asked to talk to the class on a topic chosen by you or your teacher.

In order to be successful you will reflect on your own skills and support your peers in their learning

too. The teacher will also be giving you clear, achievable targets at every stage of the learning sequence to ensure that you are on track and challenged appropriately.

You will develop a Folio of work to demonstrate the development of your skills. This folio will be made up from a variety of the different experiences and outcomes that you have undertaken during the year.

You will be assessed by your teacher through ongoing observation of your class work, engagement with tasks and peers and an end of unit assessment where you get to demonstrate your acquired skills.

Homework requirements

The time that you spend on homework will vary depending on the area of the course. You should aim to develop your own skills at home through reading a variety of different texts. This could be through novels, short stories, plays, poems, newspaper and magazine articles, comics, letters, websites, blogs, podcasts, films, manuals.

Your teacher may also set you work to enhance the learning that you have experienced in the class.

Welcome to English. We hope that you enjoy developing the skills of Reading, Writing, Listening and Talk knowing that you are best preparing yourself for a successful future beyond school.

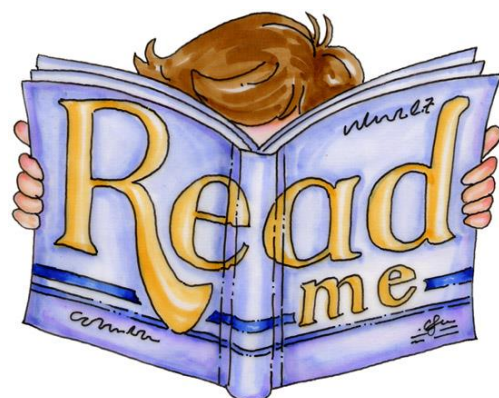

English – S4

Clear and effective communication skills are so important for your success not only in school but also in life and work. This year you will develop all the skills required for communication: Reading, Writing, Listening and Talk in a variety of engaging ways.



National 4	National 5
<p>Course outline</p> <p>The course offers learners opportunities to develop a wide range of skills. In particular, the course aims to enable learners to:</p> <ul style="list-style-type: none"> • listen, talk, read and write • understand, analyse and evaluate texts • create and produce texts • apply knowledge and understanding of language 	<p>Course outline</p> <p>The course offers learners opportunities to develop and extend a wide range of skills. In particular, the course aims to enable learners to:</p> <ul style="list-style-type: none"> • listen, talk, read and write • understand, analyse and evaluate texts • create and produce texts • apply knowledge and understanding of language
<p>Internal Assessment</p> <p>Analysis & Evaluation Unit: Reading assessment Listening assessment</p>	<p>Coursework</p> <p>Portfolio: 1 piece of either creative or discursive writing – 30%</p>
<p>Creation & Production Unit:</p> <p>Writing assessment</p>	<p>SQA Exams</p> <p>Paper 1 – Reading for UAE – 30% Paper 2 – Critical Reading – 40%</p>
<p>Homework</p> <p>Your teacher will set you work to enhance your learning that you have experienced in class.</p> <p>The time that you spend on homework will depend on the unit of work that you are undertaking. Homework may consist of creating an essay or a presentation or finishing off work that was not completed in class.</p> <p>You should aim to develop your own skills at home through reading a variety of different text. This may take the form of novels, short stories, plays, poems, comics, letters, websites, blogs, podcasts, films, manuals or newspaper and magazine articles.</p>	

ESOL - English for Speakers of Other Languages – S4

This qualification is for pupils whose first language is not English and it assesses Reading, Writing, Listening and Talking. The topics covered are relevant to everyday work, study and social situations. Students will study a wide range of topics covering everything from current world affairs to aspects of their daily lives. The course will be offered at levels National 4 and National 5.

The course is ideal for students who find English challenging because they are bilingual and are still developing their English. Often, bilingual pupils perform better in ESOL than they do in the English. The course is delivered in school so there is no need to travel to other schools/colleges.

The ESOL qualification is widely accepted by universities and it is accepted as an equivalent of the English qualification for many courses. It may be worthwhile to check university websites to check different course acceptance criteria in relation to ESOL.

Finally, S4 pupils will have the opportunity to continue ESOL in S5/6 at National 5 or Higher level.

	National 4 & 5 — ESOL
Entry Point	English as an Additional Language Consultation with SfL/EAL
Course Details	<p>The Course offers opportunities to develop and extend a wide range of skills. In particular, the Course aims to enable learners to develop the ability to:</p> <ul style="list-style-type: none"> • read, write, listen, and speak, in English • understand and use English language • apply knowledge and understanding of English language <p>These skills will be taught by exploring the following topics:</p> <ul style="list-style-type: none"> • everyday life • work • study
National 4 All Internal Course Assessment	Internal assessments in: listening, speaking, reading and writing
National 5 External Exam Details	Component 1: listening; reading and writing Component 2: speaking and listening

Geography – S3

Why Choose Geography?

Geography inspires pupils to become global citizens by exploring their own place in the world, their values and responsibilities to other people, to the environment and to the sustainability of the planet. Geography equips you with a broad range of skills for learning, life and work such as teamwork, independent enquiry and creative thinking - all highly valued by colleges, universities and employers.

What you will study:

You will build on the topics covered in S1&2, continuing to look at the Human and Physical Environment as well as Environmental Issues. S3 units will include climate change, weather, urban studies.

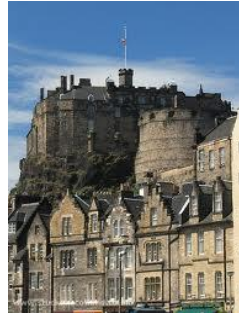

Homework

You will be assigned regular homework activities. These may include creative writing; gathering information; answering questions and revision.

Assessment

You will be regularly assessed in a variety of ways including - self and peer assessment; teacher observation; ongoing assessment of class work & project work.

Where can Geography take you?

Geography has a unique position in the curriculum; it fully embeds skills in literacy and numeracy and creates a bridge between the social and natural sciences.

Careers with Geography

- *Accountancy & Finance
- * Health & Education
- * Urban Planning
- * Law
- *Advertising & Market Research
- *Meteorology
- * Armed Forces
- * Retail Management
- * Engineering
- * Tourism & Sport
- * Primary & Secondary Teaching
- * Politics



... and lots more

Geography – S4

About the course

Geography in S4 will build on what you have learned in S1-3. You will continue to look at the Physical and Human environments as well as a range of Global Issues. You will develop a range of Geographical skills and techniques and be given opportunities to carry out fieldwork.



<p><i>What you will study:</i></p> <p>National 3, 4 & 5 consist of 3 units:</p> <ol style="list-style-type: none"> 1. Physical Environment Glaciation and Coastal Landscapes; key features of these landscapes; land use and management of these landscapes; weather. 2. Human Environment Developed and developing world cities; world population distribution and change; issues and changes in rural and urban landscapes 3. Global Issues Climate Change & Health 	 <p>Homework</p> <p>All pupils will be issued with regular homework. This may take the form of revision of class work; research tasks; practice questions and independent fieldwork.</p> <p>Fieldwork is carried out in school grounds, locally in the city and further afield, where opportunities arise.</p> 										
<p>National 4 Assessment</p> <p>Internal – one assessment per unit</p> <p>External – none</p> <p>Added Value unit – individual research project which is internally marked under guidance from the SQA</p>	<p>National 5 Assessment</p> <p>Internal – regular end of unit assessments</p> <p>External –</p> <ol style="list-style-type: none"> Question paper worth 80 marks Assignment write-up on a topic you have prepared beforehand worth 20 marks. 										
<p>Examination Information</p> <p>National 4 has no final exam – the course is pass/fail based on the internal assessments.</p> <p>National 5 has a final SQA exam and an assignment. Pupils are awarded a grade A-D based on a total mark of 100 from these two.</p>	<p>Careers with Geography –</p> <table border="0"> <tr> <td>Accountancy & Finance</td> <td>* Armed Forces</td> </tr> <tr> <td>* Health & Education</td> <td>* Retail Management</td> </tr> <tr> <td>* Urban Planning</td> <td>* Engineering</td> </tr> <tr> <td>* Tourism & Sport</td> <td>* Law</td> </tr> <tr> <td>*Advertising & Market Research</td> <td></td> </tr> </table>	Accountancy & Finance	* Armed Forces	* Health & Education	* Retail Management	* Urban Planning	* Engineering	* Tourism & Sport	* Law	*Advertising & Market Research	
Accountancy & Finance	* Armed Forces										
* Health & Education	* Retail Management										
* Urban Planning	* Engineering										
* Tourism & Sport	* Law										
*Advertising & Market Research											

Graphic Communication – S3 & S4

Why Choose Graphic Communication?

Graphic Communication gives you the opportunity to:

- develop more complex manual technical drawing skills
- develop more complex computer graphics skills
- produce a graphic presentation of a commercial product
- develop a knowledge of the use of graphic communication in industry



Project work

- 2D and 3D computer aided drawing (CAD)
- Desk top publishing (DTP)
- Knowledge of use of CAD in industry



How is the course organised?

You will work through a series of drawing topics. At the end of each topic you will do a mini project demonstrating the use of the type of graphic in commerce or industry.

How are you assessed?

By the end of S4 you will have completed two Units and projects:



Unit 1: 2D Graphics

- orthographic views
- geometric drawing
- engineering drawing
- colour illustration techniques
- DTP

Unit 2: 3D Graphics

- Oblique, isometric & planometric views
- Perspective sketching
- 3D computer modelling
- 3D promotional graphics

How is the Course assessed?

At the end of S4, students working at National 5 level will sit an SQA exam and gain a course award.

Students working at National 4 level will gain a course award based on work produced in school.

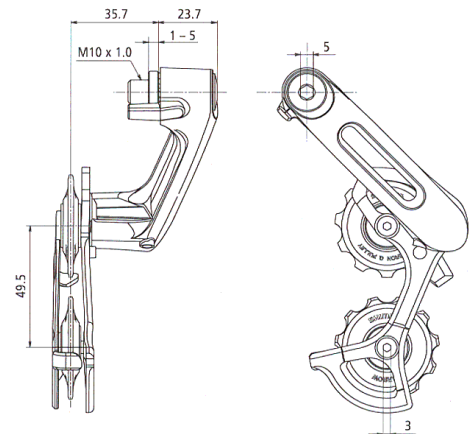

Career Opportunities

As well as being a desirable qualification for some college and university courses, Graphic Communication is essential for many careers and very useful for a great many more. Typical careers include:

- industrial draughting
- engineering
- graphic design
- architecture and building services
- product design
- interior design

History – S3

Why Choose History?

Are you interested in:

- Understanding world issues today?
- Learning more about your heritage?
- Discovering how your world has developed?
- Acquiring skills which will help you in a variety of careers?
- Studying a subject which can grow into an enjoyable lifelong interest?

**YES?
Then choose History!**



You will learn how to judge how reliable and how valuable these sources are. You will form opinions, debate issues and listen to other points of view. You will investigate one or two topics in more detail.

How are you assessed?

At the end of each topic you will be assessed on your knowledge and understanding of the topic and your ability to evaluate historical evidence. In addition you will be assessed through your teachers' ongoing observation and your input into the project activity.

Homework

You will be assigned regular homework activities. These may include creative writing; gathering information; answering questions and revision.

How is the course organised?

In S3 you will study 2 units of history. These will include the struggle for Civil Rights in America and the causes of World War One.



How will you learn?

You will examine evidence from the past using a variety of sources – written and visual.



History – S4

About the course?

History in S4 will build on what you have learned in S1-3. You will continue to look at a range of Historical issues, drawn from Scottish, British as well as European and World themes. You will develop a range of Historical skills and techniques and be given opportunities to carry out research based topics.

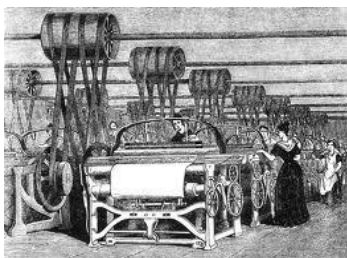

What you will study:

National 3, 4 & 5 consist of 3 units:

1. The Era of the Great War, 1900-1928

Scots on the Western Front
 Domestic impact of war: Society and Culture
 Domestic impact of war: Industry and Economy
 Domestic impact of war: Politics

2. Changing Britain, 1760-1900

Health and Housing; Industry – textile factories and coal mines; Transport – canals and railways; Pressure for democratic reform up to 1884.

3. Hitler and Nazi Germany 1919-1939

Weimar Germany; Nazi rise to power; Nazi control of Germany; Nazi social and economic policies.

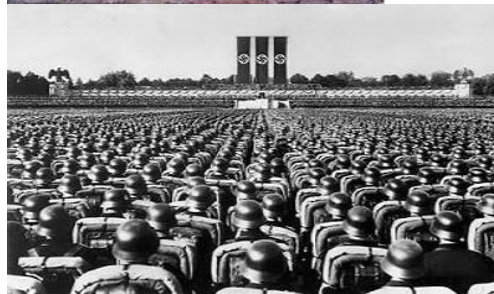

Homework:

All pupils will be issued with regular homework. This may take the form of revision of class work; practice questions and independent research-based assignments.

National 4 Assessment

Internal – one assessment per unit

External – none

Added Value unit – individual research project which is internally marked under guidance from the SQA.

National 5 Assessment

Internal – regular end of unit assessments

External –

- i. Question paper worth 80 marks
- ii. Assignment write-up on a topic you have prepared beforehand worth 20 marks.

Examination Information

National 4 has no final exam – the course is pass/fail based on the internal assessments.

National 5 has a final SQA exam and an assignment. Pupils are awarded a grade A-D based on a total mark of 100 from these two.

Careers with History

- * Archaeologist
- * Researcher
- * Civil Service
- * Insurance and Risk
- * Advertising & Market Research
- * Teaching
- * Armed Forces
- * Retail Management
- * Publishing
- * Law

HE – Practical Cookery – S3

Why Choose Practical Cookery?

Aims of course

To provide opportunities for learners to:

- Become familiar with a range of practical skills, food preparation techniques, cookery processes and textile construction skills.
- Follow flow charts/instructions to produce items; including dishes/meals and complimentary food promotion fabric textile display items, (eg Tartan goodie bags to promote Scottish Cuisine).
- Develop an awareness of the impact that the choice of ingredients has on health and wellbeing
- Develop an awareness of the importance of using local, seasonal, sustainable produce
- Understand and apply safe and hygienic routines
- Explore opportunities to design products using recycled materials

Description of the Course

The course consists of:

- Cookery Skills, Techniques and Processes: Food for the Seasons
- Skills, Techniques and Processes: Scottish Produce Promotion
- Understanding and Using Ingredients for Organisational Skills for Cooking

The main focus of these units is to give learners opportunities to develop practical related knowledge, understanding and skills, and to use them at home, in the wider community and, ultimately, in employment. Learners will produce food and textile items and become aware of issues affecting society, such as seasonality of produce, economic and sustainable food choices. Throughout the course learners will be provided opportunities to

design and make items to mark calendar events, eg Christmas and Easter.



Future progression routes in the subject

In the senior phase, this course leads to Practical Cookery, (National 4 and 5 level) and Practical Cake Craft, (National 5 level).

Homework

Homework will be set throughout the course as:

- Research/assignments
- Theory tasks; short response answers

Practical tasks; practice and evaluations

Additional Information

The course contains a significant practical element therefore a keen interest in skill development is essential. Although this is a very practical course there is an element of related theory/written work involved. The course uses real-life hospitality contexts, which makes it relevant to the world of work. The course develops a range of essential transferable skills which will stand students in good stead regardless of the career path they choose.

Home Economics: Practical Cookery – S4

Why Practical Cookery?

This course is suitable for pupils with a genuine interest in cookery and the food industry and aims to develop your practical skills.

The course provides progression to other SQA qualifications, further study, employment or training.

The main purpose of this course is to develop your practical cookery skills and knowledge of and understanding of ingredients.



We cook almost every lesson; this is a very practical course set against industry standard. It is physically demanding and we work at a very fast pace.

Results are immediate and of course you get to take all the food home!

What does the course involve?

The National 5 course comprises 3 areas.

The National 4 course comprises 3 units:

Cookery Skills, Processes and Techniques

You will develop your cookery skills, food preparation techniques and ability to follow cookery processes.

You will develop an understanding of the importance of safety and hygiene and the ability to follow safe and hygienic practises at all times.



Understanding and Using Ingredients

You will develop your knowledge of ingredients and their uses.

You will also learn about sustainability, the responsible sourcing of ingredients and the impact your choices have on health and wellbeing.

You will learn to develop the ability to select and use a wide range of appropriate ingredients in the preparation of dishes and to do so safely and hygienically.

Organisational Skills for Cooking

You will develop your planning, organisation and time management skills.

You will plan, produce dishes and meals for specified occasions working safely and hygienically. You will also evaluate the process and the product.

Assessment

National 4 units are assessed on a pass/fail basis within school and may be assessed unit by unit or by combined assessment.

Both courses will be assessed by means of practical exam with an SQA verifier. The National 5 course will also have a written exam.

Homework

Homework will be based on practical work and research.



Mathematics – S3

Introduction

All students will study Mathematics in S3. The course will build on the work done in S2. Students will continue to have the opportunity to experience the Curriculum for Excellence outcomes at Level 3 and 4.

Course Organisation

The course is organised into units each covering a number of experiences and outcomes from the three main areas of Mathematics:

- Number, Money and Measure
- Shape, Position and Movement
- Information Handling

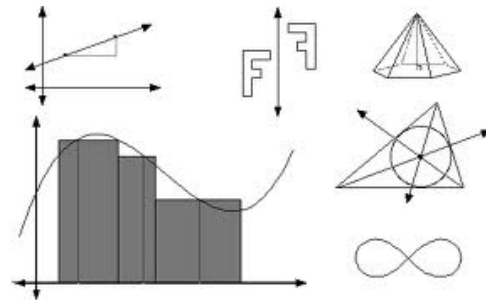

Assessment

There will be an assessment at the end of each unit. These assessments are good indicators of progress. They are used to provide feedback on areas of strength/weakness.

Homework

Students will be expected to do two main types of homework

- Formal; ink exercises. These will be checked by the teacher.
- Routine; revising for tests, completing class work, etc



Next Steps

In S4 students will follow NQ courses at Levels 3, 4 or 5 depending on their progress in S3.

Calculators

The SQA expects scientific calculators to be used in exams. Having your own scientific calculator is essential for Mathematics.



Mathematics – S4

Introduction

All students in S4 will continue to study Mathematics in S4. There are 3 levels of course being offered. Our students will study at a level which builds upon their prior attainment in S1 to S3.

The levels of study will be:

- National 3 Applications of Mathematics
- National 4 Mathematics
- National 5 Mathematics



Course Organisation

Each course is organised into units each covering a number of different mathematical topics. All units will:

- Motivate and challenge learners by enabling them to select and apply mathematical techniques in a variety of mathematical and real-life situations
- Equip learners with the skills needed to interpret and analyse information, simplify and solve problems and make informed decisions.

Assessment

In all courses there will be an assessment at the end of each unit. Passes in these units will receive credit from the SQA but the requirements to achieve an overall award are:

- For an overall award at National 3 Applications of Mathematics all the unit assessments must be passed. There is no final exam. Students who are making good progress will be given the opportunity to attempt some units at National 4 Applications of Mathematics.
- For an overall award at National 4 all the unit assessments must be passed then an internal exam passed. The overall result for the course will not be graded but will simply be pass or fail.
- For an overall award at National 5 there is an external exam. The overall result for this course will be graded.

It is SQA policy that students may only have two attempts at unit assessments unless there are exceptional circumstances.

Homework

Students will be expected to do two main types of homework

- Formal; at least one exercise per topic. This will be usually be checked by the teacher.
- Routine; revising for tests, completing classwork, etc.

Calculators

At National 4 and 5 having your own scientific calculator is essential.

Next Steps

In S5/6 students can continue to study Mathematics. The level of study is dependent on prior achievement. To study at National 5 level students will have achieved an overall award at National 4 and to study at Higher students will have achieved an overall award at National 5.

Media S3 & S4

Why chose Media?



In Media you will explore and conduct analysis into film and media – how it is created and by whom and how different media content engaged a target market. You will undertake film making projects and develop skills and techniques applied to a variety of genres. Media is offered at both N4 and N5 level in S4 and develops a variety of skills that will prepare you for the world of work and further study.

Media teaches you:-

- Planning and time management
- Group work
- Leadership
- Manage your own learning
- Problem Solving
- Presenting skills
- Film making

How is the course organised?

The course is organised into projects of varying lengths. In S4 you will complete and assignment and a written exam paper analysing media content.

What kind of things will you be doing?

In media you will engage with a variety of content; film making, creating advertising and online media content and TV. You will learn how to create different media for specific audience and genres and learn about the organisations that produce media content. You will also have the opportunity to work with media professionals to enhance your learning.

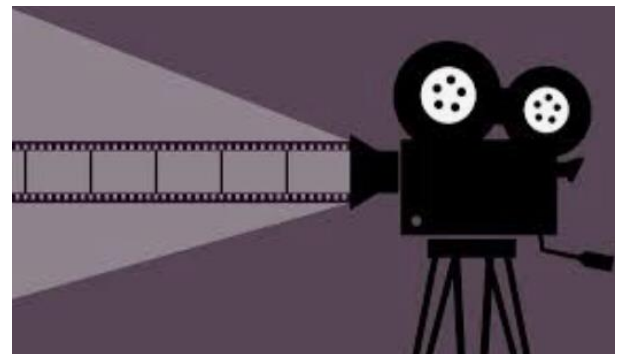

How are you assessed?



Throughout S3 and S4 your teacher will assess your progress through observational checklists, peer evaluation and folio tasks. You will receive regular feedback so you know how to improve your work.

Homework Requirements

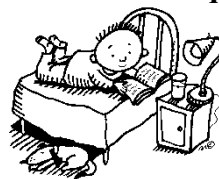

You will be set regular homework Typically, this will be research-based tasks in addition to writing up notes and responding to questions.

Modern Languages – S3

Pupils entering S3 have a choice to continue studying Modern Languages. Pupils will have studied French and Spanish during the course of S1 and S2 and will be able to build on the skills they

Why study a Modern Language?

- Studying a Modern Language helps you to understand people from another culture.
- More and more companies look for future candidates with a qualification in a Modern Language.
- Many University courses require a Modern Language as part of the entry qualification and value this highly when looking at applications
- **Related Careers / Industries:** Travel, Tourism, Law, Sport, Fashion, IT, Business Management, Teaching, Translation, Interpreter, Politics and many more!

How is the course organised?

The course is divided into four Contexts.

Within each context there are different units of work.

1. Society
 - Relationships (Friends and Family)
 - Home Area
 - Media and Technology
 - Healthy Living
2. Learning
 - School Subjects and Opinions
 - Ideal School
 - Describing your School
 - Comparison of School systems
3. Employability
 - Part-Time Jobs
 - Pocket Money
 - Future Plans
4. Culture



have already developed in S3. They can choose French or Spanish, or even if they would like the opportunity to become a dual linguist.

- Holidays (Past, Present and Future)
- Festivals
- Traditions



What kind of activities will you be doing?

- Listening
- Talking
- Reading
- Writing
- Projects
- Digital Learning
- Group Work
- Paired Work
- Active Learning



How are you assessed?

- Listening
- Talking
- Reading
- Writing
- Project



Please Note: All Assessments in S3 are internal

Homework:

- Learning vocabulary & grammar
- Reading exercises
- Listening exercises
- Talking preparation

If you are able to, it would also be good to have your own dictionary as this will help you to prepare for the final exam but we have plenty available in school.

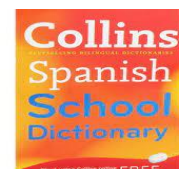
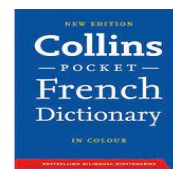

Modern Languages – S4

“If you talk to a man in a language he understands, that goes to his head. If you talk to him in his own language, that goes to his heart.” –Nelson Mandela



- **Languages for life**

Being able to speak another language is an important life skill and is a skill highly valued by employers.

- **Communication skills and adaptability**

Learning how to interact with speakers of other languages means you are less likely to be stuck in one mode of thinking.

Course Overview

The course will build on learning and language skills from S1 -S3. We will cover a variety of topics in the contexts of **Society, Education, Employability and Culture**.

Assessments

National 4

Internal

Learners will be required to provide 1 piece of evidence in all 4 skills- Reading, Writing, Listening, Talking, using straightforward language.

National 5

Course Assignment

Learners will provide evidence of their Writing skills, by producing a piece of writing in the Modern Language. Learners will plan, create a piece of writing on a topic of their choice. This is sent to SQA to be marked externally.

The Course Assessment

The final exam will consist of the following elements. Pupils will have opportunities to practice these skills throughout the year in preparation for the final exam.

Reading: Pupils will read 3 passages in the foreign language and then answer questions in English. This is worth 30 marks.

Listening: Pupils will listen to 1 dialogue and 1 conversation in the foreign language and then answer questions in English. This paper is worth 20 marks.

Writing: Pupils will be asked to prepare a “Job Application”. The first four bullet points are always the same but the last 2 change every year. We give pupils examples of these to help them prepare for the final exam. This exam is out of 20 marks.

Talking: Pupils are asked to prepare a 1 – 2 minute presentation on a topic of their choice. There will then be follow questions which will lead into a discussion of 5-6 minutes. This is internally assessed and marked and then the marks are sent to the SQA. This is worth a total of 30 marks.

Why Choose Modern Studies?

Modern Studies helps you to understand the most important issues in the world today. It helps you gather information about these issues, evaluate the information you have and most importantly, it helps you make your own mind up and come to your own conclusions about these issues. It is often said in Modern Studies that as long as you can support your argument with facts, you are never wrong! For example, what is your opinion on the war against terrorism?

Modern Studies is an **excellent qualification** for higher education and work. There are many university courses and careers that Modern Studies can lead to in Law, Medicine, Journalism, Accountancy and Finance, Politics, Sociology, Personnel, the Army/Navy/Air Force, Civil Service, Policy, Teaching, Social Work and many more.

Some of our most recent former Higher pupils are currently studying Law (Edinburgh University), International Relations (Edinburgh University), Nursing (Queen Margaret University), Education (Stirling University) and some are working for the NHS, Scottish Government, and training for the RAF.

How is the course organised?

There are three units which will enhance and extend the work of S1/2 and will also lay the foundations for the course in S4.

1. Political Issues in the UK

- Taking part in a democracy
- Actions of pressure groups

2. Social Issues in the UK

- Groups living in poverty eg families and the unemployed
- Causes and impact of crime
- Role of the police

3. International Issues in the USA

- Social and economic inequality
- Immigration

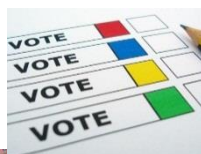

- Capitalism versus Communism
- Terrorism

What will I learn in Modern Studies?

The Modern Studies course teaches pupils the knowledge they need to understand social and political issues. It also involves the skills of evaluating sources, analysing information and making informed decisions. We also as a department emphasise and develop the literacy skills of pupils.

These transferable skills benefit pupils across the curriculum, for example with close reading or discursive writing in English.

How are you assessed?

- End of unit assessments
- Ongoing observations especially in group work
- Project work / research reports
- Peer assessment

Homework

Homework will be topic based with an emphasis on keeping up to date with current affairs.

Modern Studies in S4

In S4 the topics we cover are:

- Crime and Law
- American Politics
- UK Politics



S4 pupils take part in the Street Law programme run by the Law Society of Scotland. The programme complements our S4 Crime Unit and involves lawyers coming to the school to run active participatory sessions about the law and legal process.

Modern Studies – S4

About the course

Modern Studies in S4 will build on what you have learned in S1-3. You will continue to look at Politics and Social Issues in the UK as well as the USA. You will develop a range of Modern Studies skills and techniques and be given opportunities to carry out your own research.

<p>What you will study:</p> <p>National 3, 4 & 5 consist of 3 units:</p> <ol style="list-style-type: none"> 1. Democracy in Scotland and the UK UK Government; Scottish Government; participation in politics; the media; rights and responsibilities in society. 2. Social Issues Crime: types of crime; causes of crime; the impact of crime on individuals and communities Tackling crime: the role of the police; the criminal justice system in Scotland and different courts; sentencing, juvenile justice. 3. International Issues USA: socio-economic and political study of the USA, including contemporary issues. 	 <p>Homework:</p> <p>All pupils will be issued with regular homework.</p> <p>This may take the form of revision of class work; practice questions and independent research tasks.</p> <p>There will also be an expectation that pupils will keep up to date with current affairs.</p>
<p>National 4 Assessment</p> <p>Internal one assessment per unit</p> <p>Added Value unit – individual research project which is internally marked under guidance from the SQA.</p>	<p>National 5 Assessment</p> <p>Internal regular end of unit assessment</p> <ol style="list-style-type: none"> Question paper worth 80 marks Assignment write-up on a topic you have prepared beforehand worth 20 marks.
<p>Examination Information</p> <p>National 4 has no final exam – the course is pass/fail based on the internal assessments.</p> <p>National 5 has a final SQA exam and an assignment. Pupils are awarded a grade A-D based on a total mark of 100 from these two.</p>	<p>Careers with Modern Studies</p> <ul style="list-style-type: none"> * Law * Accountancy & Finance * Police * Armed Forces * Health & Education * Politics * Primary Teaching * Social Policy * Advertising & Market Research * Tourism & Sport

Music – S3

Why Choose Music?

Music develops your skills and abilities in Performing, Composing and Understanding Music. It provides opportunities to play in a group environment eg choir, orchestra, band. It is also a valuable addition to college & university applications and opens doors to a wide range of careers both within and outside the arts eg Creative and Media work, Events Management, Music Teaching, Primary Teaching, Medicine, Law, Sound Engineering etc.



Music teaches you to:



- Present yourself successfully
- Perform confidently in front of others
- Work with others and contribute effectively
- Think creatively and critically
- Be disciplined and to work independently
- Evaluate and improve your performance
- Develop your digital skills

All of these are skills are highly desirable for learning, life and work after school

How is the course organised?

- In S3 you will study the three areas of Music – performing, understanding music and composing. You will continue to develop your skills on your chosen instrument(s) from S2.

What kind of things will you be doing?

- The course is performance based. You will play 2 instruments, which can include singing. You will have the opportunity to choose music to play including genres & music by singers/bands which interest you.
- You will write your own piece of original music using either computer software or iPad software.
- You will also listen to and learn about a variety of different musical styles and cultures.



How are you assessed?

Performing - Your teacher will listen to you playing your instruments and you will receive regular verbal and written feedback on your practical work.

Understanding Music - You will complete 3 written assessments throughout the year.

Composing – You are required to submit a short composition at the end of the year.

Homework

Your main form of homework is to practise your instruments! You should aim for 3 x 30 minute sessions each week.

There also will be occasional written assignments on musical styles / genres.

Music – S4

About the course

Through music, learners have rich opportunities to be creative and to experience inspiration and enjoyment. Performing and creating music will be the prominent activities for all learners. Through these activities they develop their vocal and instrumental skills, explore sounds and musical concepts, and use their imagination and skills to create musical ideas and compositions. They can develop their understanding and capacity to enjoy music through listening to musical performances and commenting on them. They use ICT to realise or enhance their composition and performance, and to promote their understanding of how music works.

Although the courses are split into several units they can be divided into three areas: Understanding Music, Performing and Composing. In Understanding Music, pupils will broaden their knowledge of music by listening to and analysing music from a wide range of styles, including those from other cultures. They will apply this learning in Composing where they will complete a series of short projects to create original pieces of music using a variety of approaches. In Performing, pupils will learn two instruments (or one instrument and voice) and they will participate in classroom performances throughout the year.

A wide range of learning and teaching approaches is used in the department. These include whole class teaching, group activities, ICT presentations and individual work. The course is designed to allow many opportunities for collaboration and active learning.

Assessment

A continuous assessment approach will be used throughout the course. Pupils will take part in assessed classroom performances throughout the year and their composition work will be continually monitored using observational checklists. Their understanding of music will also be evaluated through the use of questioning techniques, discussions and listening tests.

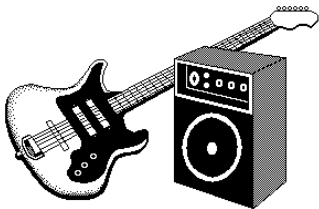

At National 4 level pupils will be required to pass units in Understanding Music, Composing Skills and Performing Skills. These will be internally assessed and will be subject to verification by the SQA.

In National 4 only, pupils will also be required to pass an internally assessed Added Value Unit in Music Performance where pupils will prepare and perform a programme of music on both

of their instruments (or one instrument and voice). National 4 courses

are not graded.

Exam Information

In National 5 only, an SQA examiner will visit the school to assess a performance given by each pupil on both of their instruments (or one instrument and voice). This performance will be worth 50% of their final grade. Pupils have to complete a composing assignment which is worth 15% of the final grade. Pupils will also be required to sit a question paper to test their knowledge of music concepts, notation and styles. This question paper will be set and marked by the SQA and will be worth 35% of the final grade.

Homework

Pupils will be required to practise their instruments (or instrument and singing) outwith class time on a regular basis and this will constitute a large time commitment from pupils. They will also be given notation, concept and analysis homework from time to time. Most of the composition work will be completed in school but pupils may sometimes be asked to complete tasks they have started in class as homework.

Possible Careers

In addition to obvious careers in the music, the course design allows pupils to develop a broad range of skills for learning, life and work such as personal learning skills, thinking skills and using ICT. Regular performing develops self-confidence and sustaining a practice routine on an instrument or voice requires self-discipline, perseverance, planning and the ability to identify areas for improvement. All of these are valuable skills which attract prospective employers.

Music Technology S3 & S4

Why Choose Music Technology?

S3/S4 Music Technology is a fun and exciting course which focuses on the recording, editing, and mixing of music. Pupils will have the chance to experiment with top of the range production software as well as good quality recording equipment. Music Technology is a mainly practical subject which requires some creativity as pupils will be creating their own radio broadcast, sound for game and sound effects for film. Pupils will also learn about the music of the past two century's, ranging from current pop music all the way back to old school Blues and Hip Hop.



Music Technology teaches you to:

- Become resilient with technology and its malfunctions
- Work with others and contribute effectively
- Think creatively and critically
- Be disciplined and to work independently
- Reflect and evaluate
- Develop your general IT skills



All of these are skills which are highly desirable for learning, life and work after school.

How is the course organised?

- S3 will be mainly practical, you will be working with software and hardware to develop your recording and mixing skills. There will also be time dedicated to listening. You will listen to and explore different styles of music from the past two centuries. You will also explore the world of Intellectual Property and study some Copyright cases.
- In S4 you will undertake the N4/N5 course – you will complete 2 assignments during the year in addition to a written exam. In S4 you will continue to develop your practical skills.

What kind of things will you be doing?

- You will learn how to record all instruments from guitars and flutes to drumkits and voices. You will mix and edit your recorded tracks as well as pre-recorded tracks.
- You will create Radio Broadcasts, Audio Books, Mashup's, Sound for Game and Sound for Film.

How are you assessed?

Practical – You will submit 3 different projects over the year which will assess your skills.

20th and 21st century Music – You will complete several listening assessments, all based on the styles of music covered

Physical Education – S3

In S3 you will receive two periods of core Physical Education per week.

The aims of core PE:

- We want you to develop a positive attitude towards physical exercise.
- We want you to understand the importance of a healthy lifestyle.
- We want you to develop good team-working skills.
- We want you to experience enjoyment of sport and physical activity, both now and in the future.

The core programme builds on the course from S1 and S2 and continues to focus on the outcomes and experiences of the 'Curriculum for Excellence'. However, in S3 you will be given more choice as to which activities you would like to participate in.

You will make a choice from a list of activities and the course will be based around the most popular choices. Each term you will choose an activity from a different category, these being:

- Team Activities
- Individual Pursuits
- Creative Activities
- Fitness and Health Related Activities
- Summer Activities



Assessment

You will be assessed continually throughout each activity block and decisions will be made in relation to how well you are achieving the outcomes of 'The Broad General Education'. Comments will also be

made on your progress in performance, your participation rate and your effort.



A variety of assessment methods may be used such as teacher observation, self and peer evaluation, video analysis and live performances.

Homework

There is no specific written homework for core PE, although your teacher may give you a research task on occasion in order to help support the work you are doing in class. Your main homework in PE will be to become involved in regular physical activity outside of school.

Examination Courses in Physical Education

There are exam courses available in PE in S4. If you are interested in one of these courses, you can choose elective PE in S3 which will give you an extra three periods per week. During this time you will cover some extra PE work which will help you prepare for your course in S4.



Possible Careers

Following courses in Physical Education can lead to a variety of careers such as Professional Sportsperson, PE teaching, Sports Coaching, Sports Physiotherapy, Sports Analyst, Leisure Management, Armed Forces, Police Service and the Fire Service.

Physical Education – S4

About the Course

The purpose of this course is to develop, demonstrate and improve your practical skills in physical activities. You will develop knowledge and understanding that you will be able to apply in order to improve your overall performance in a number of activities. The course is largely practically based which means you will acquire much of this knowledge and understanding through participating in the activities. You will be required to do classroom-based work at times.

Through this course you will also have the opportunity to develop team-building skills and enhance your ability to compete, co-operate and collaborate.

National 4/5 PE provides progression to other SQA qualifications and is suitable if you have an interest in and enthusiasm for sport or if you are considering further education or a career in the sport/leisure industry. Pupils will be presented at either National 4/5 depending on the level of their attainment in coursework, assessments and practical performance.



What does the course involve?

The course consists of two areas at National 5 and three areas at National 4:

Area/Unit 1: Physical Education: Performance

This area is designed to improve your level of performance in a number of Physical activities/sports. Activities will be decided depending upon the interests of the class.



Area/Unit 2: Physical Education: Factors Impacting on Performance

This area explores factors which impact on engagement and performance in physical activities. You will investigate how you can improve your performance in one physical activity through the development of two of the four main factors: PHYSICAL, MENTAL, SOCIAL and EMOTIONAL. You will reflect on and monitor your progress. At National 5 level, you will create a portfolio of evidence which will be submitted to SQA for external marking. The purpose of the portfolio is to provide evidence of the process involved in planning for personal performance development. This portfolio could include evidence in a variety of formats such as:-
a logbook, diary, development record or photographic/video evidence.

Area/Unit 3: Physical Education: Practical Activity (National 4 only)

In this area you will have the opportunity to apply your skills and knowledge previously gained to further improve your performance in one activity.



Assessment

Area/Unit 1: Performance

You will be required to **demonstrate** a basic range of performance skills in **two** activities. (At National 4 level)

Unit 2: Factors Impacting on Performance

This will be assessed through **discussion** and **written** tasks. At National 5 this will include more formal written assessments and your portfolio of evidence. The portfolio will contribute to 50% of your overall grade.

Unit 3: Practical Activity (National 4 only)

This will be assessed through **practical activities** which allow you to show the extent to which you can **apply** the knowledge and skills you have gained in the above two areas.

At **National 5** level you will complete two performance assessments which will contribute to 50% of your overall grade.

Possible Careers

Following courses in Physical Education can lead to a variety of careers such as Professional Sportsperson, PE teaching, Sports Coaching, Sports Physiotherapy, Sports Analyst, Leisure Management, Armed Forces, Police Service and the Fire Service.

Why Choose Physics?

Physics is a fascinating and enjoyable subject which is highly sought after by universities and employers. It is the Science which drives many advances that make our everyday lives comfortable and interesting – internet, mobile communication, animations, cinema, flight, medical physics and so on. Understanding Physics is made even easier when studied alongside either Chemistry or Biology.

There are a lot of discoveries still being made in Physics and various aspects of Physics are regularly discussed in the media. The S3-4 Physics course will help you to understand the issues discussed in the media and how they apply to your life.

Where Could a Physics Qualification Lead?

Physics is valuable for leading into a huge number of well-paid professions. In addition to feeding into careers in technological research, engineering and physics, it is also very useful for further study in medicine, dentistry, chemistry, music, music technology and many more. You would also be taught essential skills and understanding necessary for work as an electrician or a mechanic.

How is the course organised?

The course will be organised into 3 broad, general units. They cover

- Electricity and Energy
- Waves and Radiation
- Dynamics and Space

Within the three units pupils will undertake the outcomes at either National 3, National 4 or National 5 level.



What kind of things will you be doing?

Physics is taught through a variety of experiences. You will undertake experiments using both traditional and modern experimental techniques; you will learn collaboratively, working with others to develop your understanding; you will undertake research and computer simulations will be used to help you visualise what we cannot see. You may also have the opportunity to undertake visits to see Physics in use in industry.

How will you be assessed?

Assessment for Physics involves 3 elements:

- end of topic assessments involving knowledge and skills questions. The course is taught over 10 topics, each with an assessment
- assignment where pupils will perform practical work and produce a full written report. For National 5 this is written under exam conditions
- full course assessment for National 5

Homework

Homework will be set weekly to help you develop your understanding. Homework will take a variety of forms, including research, problem solving questions, communication tasks and revision for tests.

Practical Woodworking – S3 & S4

Why Choose Woodworking Skills?

The course will give you the opportunity to develop more advanced woodworking skills.

You will manufacture a series of projects covering a range of construction techniques.

Course Content

Flat-frame Construction

- care and safe use of hand tools
- construction of basic frame joints
- flat frame construction project (for example coffee table etc)

Carcass Construction

- knowledge of natural & manufactured materials
- construction of basic carcass joints
- carcass construction project

Machining & Finishing

- safe use of fixed machine tools
- safe use of portable power tools
- working to recognised safety procedures
- wood turning (lathe) project (for example, bedside lamp, towel rail etc)

Course Project

Manufacture of a given product using all of the techniques used in the Units (for example, kitchen storage unit etc)

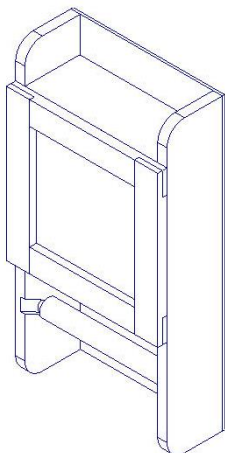

How is the course organized?

Each project has a set of working drawings that you will work from. All the craft techniques that you need to learn will be practised before the start of each Unit. Most of the time will be spent in a craft workshop doing practical activities. Learning how to work in a safe and careful manner will have a very high priority. You will be instructed in the use of hand and power tools and be expected to use them safely under supervision.

How is the Course Assessed?

Each Unit is assessed against set criteria, in class, and is awarded on a pass fail basis. At National 4, the Course is assessed using the Course Project. At National 5, the Course is assessed using the Course Project and a written exam.

The Unit assessments and the Course Project are externally verified by the SQA.

Career Opportunities

As well as teaching you useful life skills, Woodworking Skills can lead to College courses and apprenticeships in the joinery and building trades.

- Carpenters
- Craft and Fine Artists
- Ironworkers
- Jewelers and Precious Stone and Metal Workers
- Machinists and Tool and Die Makers
- Sheet Metal Workers

Why choose RMPS?

Are you interested in:

- How religions and their cultures have shaped our world?
- The moral issues facing humanity and the daily grapple between right and wrong choices?
- Exploring how we fit into the Universe?
- How philosophy can be used in its various forms to help make sense of the world?

YES?? Then choose RMPS!



How is the course organised?

In S3 you will study four units. These will include:

World Religion – Sikhism

Morality and Belief – Morality, Environment and Global Issues

Religious and Philosophical Questions- Origins and The Problems of Suffering and Evil.

What will you learn?

The RMPS course teaches pupils the knowledge they need to understand religious, moral and philosophical questions. This course will also provide you with a range of skills. These include carrying out effective research, understanding and analysing subjects from a range of perspectives, and presenting your knowledge, understanding, analysis and criticisms of the topics in the course.

How are you assessed?

- End of unit assessment
- Ongoing observation
- Presentation/Group research task



Homework

Homework will be topic based with an emphasis on describing, explaining and analysing religious and non-religious responses to religious, moral and philosophical questions.

RMPS in S4

In S4 you will study three units:

- Morality and Belief – Morality, Medicine and the Human Body
- Religious and Philosophical Questions- Miracles
- World Religion – Islam



Religious Education in the Catholic School is distinctive because of its focus on the faith development of young people within the context of a faith community. Its main purpose is to assist young people to make an informed, mature response to God's call to relationship.

This Is Our Faith is the National Curriculum for Excellence syllabus for Roman Catholic schools. It provides core learning under eight strands of faith which young people experience from Primary 1 through to S6. In addition to the core curriculum there are opportunities for certification in Religious, Moral and Philosophical Studies. Religious Education is designed to engage pupils in an educational process which will:

- Develop their knowledge and understanding of the Catholic faith
- Nurture respect for other Christian traditions and world religions
- Experience opportunities for spiritual growth
- Acquire skills of reflection, discernment and moral decision-making
- Commit to beliefs, values and actions in a positive response to God's invitation to faith.

Learners will also engage with 'Called to Love' which is the Catholic Church's education programme for sex and relationships.

Assessment of knowledge and understanding and skills will be ongoing throughout the course.

As well as academic and spiritual formation, there are opportunities for participation in the spiritual life of the school. Class liturgies, opportunities for prayer and reflection and retreats are a central part of the RE curriculum.

Science in Health – S3 & S4

National Progression Awards (NPA) are designed to develop skills related to particular careers. The Science and Health NPA is a level 4 award (at a level similar to National 4) which relates to Human Health and develops skills and knowledge which lead into careers in the STEM (Science, Technology, Engineering and Maths) sector. The S3-4 Science and Health course leads towards pupils gaining a Level 4 NPA in Science and Health by the end of S4.



The course is designed to

- Develop knowledge and understanding of Biology, Chemistry and Physics
- Develop skills in good laboratory practice
- Develop an understanding of health and safety practices
- Develop an awareness of health and wellbeing
- Prepare our young people for careers related to human health or laboratory science.

Why Choose Science in Health?

Our understanding of the human body and health is developing fast. Keeping ourselves healthy involves understanding the biology of how our bodies work, the chemistry of our cells and the physics of many of the medical techniques, such as X-rays and ultrasound. This course is designed to include Science relating to all of those areas, whilst developing investigative skills and providing opportunity to investigate the life sciences industry.

The course is assessed through internal assessment only, with class assessments, research, presentations and practical assessments. The S4 Science and Health NPA has no formal exams. Assessment will be undertaken in line with National Strategies, assessing understanding of both Science and the Skills for Learning, Life and Work.

The course is suitable for those with an interest in Science but find the pace of learning challenging at times.

Progression from the Science and Health NPA following completion in S4 would be into National 5 Biology, Chemistry, Physics or Laboratory Science or to a Foundation Apprenticeship in the STEM Sector.

Homework Requirements

Homework will be set regularly to help you develop your understanding. Homework will take a variety of forms, including research, problem solving questions, communication tasks and revision.



S2 Learning Review

Course Choice Form S3/4 2024 – 2026

Please note the following:

- Pupils will submit their course choice options online aided by their Pupil Support Leader.
- This form must be completed first and then signed by a Parent/Carer before courses can be submitted.
- Once courses have been chosen it may not be possible to change to another subject. Pupils must take time to investigate subjects and career paths to be sure about their choices.

Free Choice/Selection

Pupils will have free choice and can choose any subject on offer. However, there are some important points to consider.

- Pupils are making their choices for S3 and S4. Pupils will not be able to change their choices in S4. The subjects chosen will be the subjects that pupils sit SQA formal assessments in.
- Some subject choices may not be possible (oversubscription/clashes with other subjects/lack of numbers).
- We encourage Pupils and Parents/Carers to follow staff advice when selecting particular subjects. For example, during Parents Evening or Tracking Reports.
- Prior learning in a subject could be taken in to consideration if necessary.
- Pupils and Parents/Carers should refer to the Learner Pathways Information booklet and Parent Powerpoint Presentation for further details.
- Pupils should also think about their career path and what they would like to do when they leave school so that they understand what subjects they should be taking that will support this career choice.

All pupils must take:

- English (4 periods per week)
- Mathematics (4 periods per week)
- Religious Education (2 periods per week)
- Physical Education (2 periods per week)
- Personal Social Education (1 period per week)

In addition, five further subjects must be chosen from the options on the next page. Pupils should also select 2 reserve choices. This is in case some of their subject choices are not possible.

Pupils will be asked to choose subjects by preference. For example, if they are very keen to take French, this should be one of their first choices.

Subject Choices

Religious Education	Religious Studies				
Languages	French		Italian	Spanish	
Social Subjects	Geography	History		Modern Studies	
Science	Biology	Chemistry	Physics		Science & Health
Performing Arts	Creative Industries	Drama	Media	Music	Music Technology
CDT & Art	Art & Design	Graphic Communication		Design & Manufacture	
Business & Computing	Administration & IT		Business Management		Computing
Health & Wellbeing	Physical Education		Practical Cookery		
Wider Achievement	Princes Trust		Duke of Edinburgh		

Course Choice Sheet

Pupil Name		Tutor Group	
Pathway			
Career Choice			
Priority	Subject Choice	Subject Teacher Signature	
1	Maths	NA	
2	English	NA	
3			
4			
5			
6			
7			
Please add 2 reserve choices (by preference)			
Reserve 1			
Reserve 2			
Pupil Signature		Date	
Parent/Carer Signature		Date	
PSL Signature		Date	

These options should now be entered online using your personal login details. Your PSL with have this information.